

Prairie View Industries

Modular XP Ramp Assembly Manual

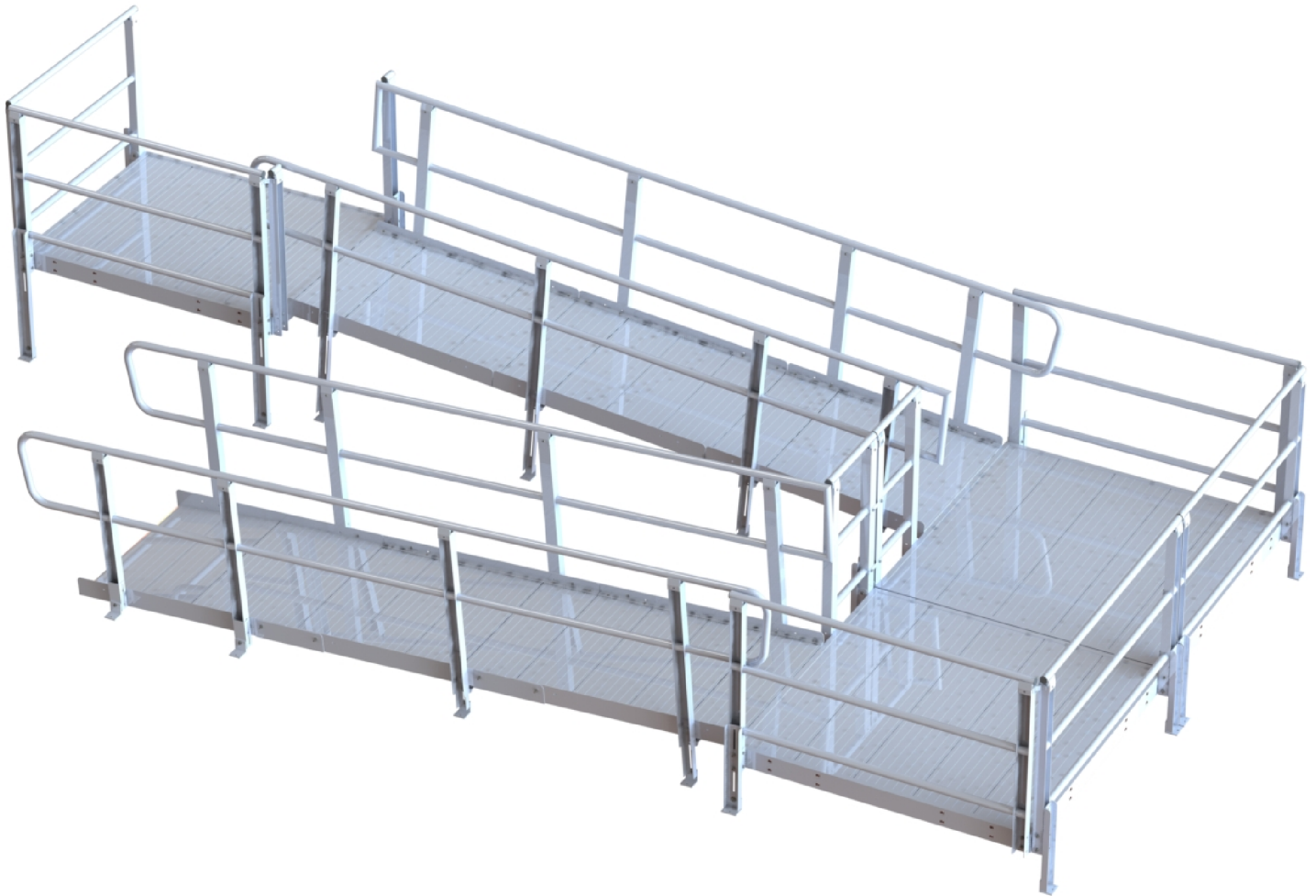

Prairie View Industries

Contents

Overview.....	2-5
---------------	-----

Section1: Tools & Hardware

1.1 Tools required.....	6
1.2 Hardware list	6

Section 2:Ramp & Platform Standard Parts

2.1 Ramp Parts.....	7
2.2 Platform Parts.....	8
2.3 Standard Platform Configurations.....	9
2.4 Optional Parts.....	10

Section 3: Platform Assembly

3.1 Handrail to Platform Attachment.....	11
3.2 Post Corner Bracket Installation.....	11
3.3 Platform Leg Attachment.....	12
3.4 Platform Under Support Attachment.....	12
3.5 Multiple Platform Base Open Side Assembly.....	13
3.6 Multiple Platform Base Assembly.....	13
3.7.1 Platform Long Leg Support-Angle.....	14
3.7.2 Platform Long Leg Support-Straps.....	14
3.8 Ramp Attachment Bracket Installation.....	15

Section 4: Ramp Assembly

4.1 Ramp Section Assembly (<i>Top Ramps</i>).....	16
4.2 Ramp Post Attachment.....	16
4.2.1 Entrance Assembly (<i>Bottom Ramps</i>).....	17
4.3 Handrail Splice.....	17
4.4 Ramp to Landing Attachment.....	18
4.5 Ramp Leg Attachment & Adjustment.....	18
4.6 Long Leg Supports (<i>Ramps</i>).....	19

Section 5: Optional Parts

5.1 Hurricane Tie Down Kit (<i>Platforms</i>).....	20
5.2 Hurricane Tie Down Kit (<i>Ramps</i>).....	21
5.3 Gate Assembly.....	22

Overview

Appearance: The PVI Modular Ramp System with handrails has a clean uncluttered appearance that will fit in most surroundings.

Low Maintenance: The all aluminum design has lifetime durability in all kinds of climates without periodic painting or renewal of preservatives. The aluminum alloys used are resistant to salt corrosion. The modular ramp system may even be used in coastal areas and cold climates that use deicers.

Permanent but moveable: The PVI Modular Ramp System serves the purpose as well or better than a permanent concrete ramp, but can still go along with the user if they move, or can be removed and resold when no longer needed. This ramp system is designed to be freestanding and totally independent of the existing structure. In many areas this simplifies compliance with local codes and in many cases eliminates permit requirements.

Flexible Modular Components: If or when the ramp is moved it is easy to add to, subtract from, or reconfigure the modular components at a new location. This feature makes the system attractive to lease/rental opportunities that may be available with insurance companies serving rehabilitation needs. It is best to use standard and/or existing components if possible. Custom designs add cost to the ramp and delay delivery. There are times when special components must be used and PVI is ready to provide the design and production assistance required.

Quick, Easy Assembly and Installation: The modular components of the PVI ramp are designed to be quickly and easily assembled with simple hand tools and set in place without the need for construction equipment. A van, pickup or small trailer is all that is needed to transport the ramp components (or shop assembled components) to the job site.

Quick and Economical Shipping: The modular components are stocked and warehoused so an order can be filled and shipped on short notice. The lightweight aluminum design and plant location make it economical to ship to any part of the country. Shipping cartons can be handled with ease.

Standard Components:

Ramps

Width: 36" Standard width; custom widths are optional

Length: Minimum length of 4'.

Ramp Surface: Aluminum planking with lateral grooves, and a knurled surface.

Curbing: 4" high curb-standard

Slope: Adjustable from 1:12 to 3:12

Platforms Turn or straight configurations:

Dimensions: 48"x60", 60"x60" standard sizes.

Height: minimum height of 4 ½", maximum height of 60"

Load Capacity: 100 lb. / sq. ft.

180 Degree turn or straight through Platform:

Dimensions: 60"x96" or 60"x120" Standard.

Height: minimum height of 4 ½", maximum height of 60"

Load Capacity: 100 lb. / sq. ft.

Overview

Slopes, Handrails and Layout Considerations

NOTE: ADA COMPLIANCE IS USUALLY OPTIONAL (GUIDELINE ONLY) FOR RAMPS TO PRIVATE HOMES

Slopes: The ADA recommended slope of 1:12 is preferred when possible. However, when space is limited or other considerations require a steeper ramp, the PVI modular system will accommodate slopes up to 3:12. Any slope selected must consider the capabilities and safety of the users and their equipment.

Handrails: ADA requires handrails on any ramp with a rise of 6" or more. The PVI Modular Ramp System is available with or without handrail; however, we recommend handrails on all but the shortest ramps unless other provisions are made for the safety and assistance of the user. Not having handrail also takes away from the overall strength of the ramp system. Some codes mandate handrail spacing and/or vertical slats. Call PVI on designs with special handrail requirements.

Layout Considerations: The usable width of a standard ramp is 36", the overall width of the ramp (from leg to leg) is 41 ¼". The length of the individual ramp segments are as follows: 3', 4', & 5'. The segments are used in combinations to make lengths from 6' and longer in 1' increments.

Shipping:

Freight Line and Freight Charges: PVI uses a combination of truck lines. Freight charges vary depending on the size and scope of the ramp system and destination. Call PVI for a price quote on a particular ramp.

Handling: All components are shipped in packages light enough to be handled with ease.

Assembly

Ramp and Platform Assembly: Complete detailed assembly instructions are included with each ramp. Assembly time for ramps is approximately one man hour per 16 foot of ramp length. Assembly time for Platforms is approximately ½ man hour. Ramps can be assembled in sub assemblies for easy transport to the job site. Site preparation, transport time and anchoring time is not included.

NOTE: During assembly do not tighten hardware all of the way until assembly is complete.

Footing and Anchoring: The PVI Modular Ramp Systems are designed to be freestanding, independent structures that do not have to be permanently attached to the building it serves. Each supporting leg is independently adjustable so any settling or heaving of the supporting surface can be adjusted quickly and easily with a single ½" ratchet. The ramps are also designed to be disassembled, moved and reassembled at a new site in a new configuration and length. Platforms must have a minimum of one leg anchored on each of the two opposite sides. Each free standing ramp must be anchored at the upper and lower end. Secure anchoring for the first pair of post at the bottom is especially important because this adds necessary strength to the lower end of the handrails. Anchoring may consist of lag screws or bolts into existing concrete, precast pads, patio pavers or poured in place.

Overview

Modular Ramp System Assembly

Step#1: Unpack all parts and make sure all parts on packing list are present.

Step#2: First assemble top platform (*platform#1*).

- (A) Select correct platform configuration from list (pg.9).
- (B) Assemble platform using parts in Section 2.2.
- (C) Set in place, level, and install leg braces if required.

Step#3: Assemble top ramp run using parts in Section 2.1(*Ramp#1*).

Step#4: Assemble next platform same as (A) (B) (C) of the top platform (*platform#2*).

Step#5: Assemble next ramp section (*Ramp#2*).

Step#6: Check all hardware to ensure it is tight.

NOTE: Some systems may only require one platform and one ramp if so skip steps 4&5.

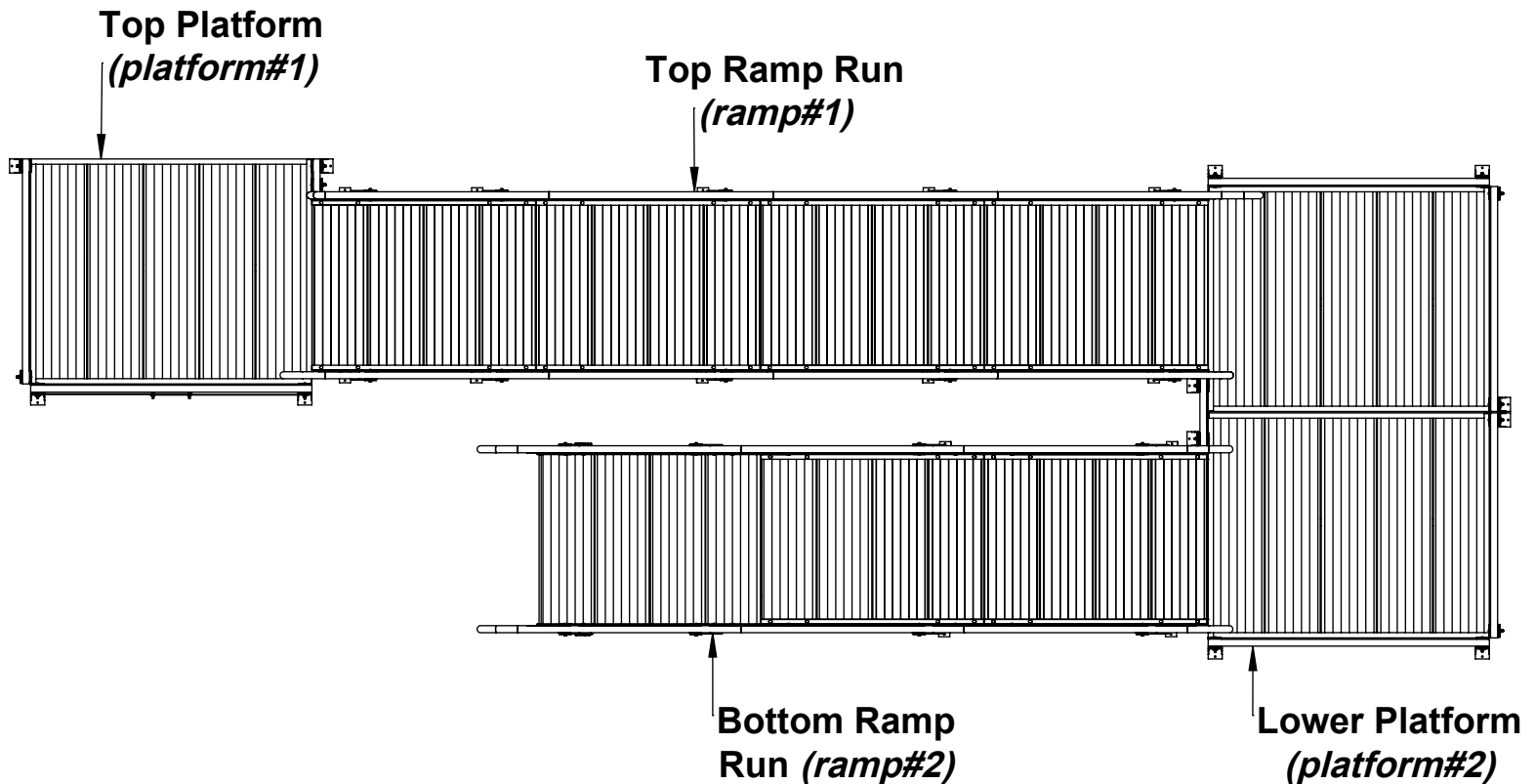

SECTION 1: TOOLS & HARDWARE

1.1 RECOMMENDED TOOLS

- Ratchet
- 1/2" Deep Well Socket
- Socket Extension
- 1/2" Wrench
- Hacksaw
- Tin Snips
- Cordless Drill
- #2 Phillips Drill Bit
- 7/16 Nutdriver Bit
- Tape Measure
- Saw Horses (two pair are recommended)
- 1/4" Masonry Bit
- 5/32 Allen Wrench
- Bubble Level

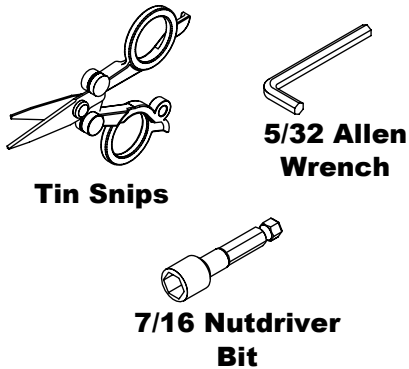
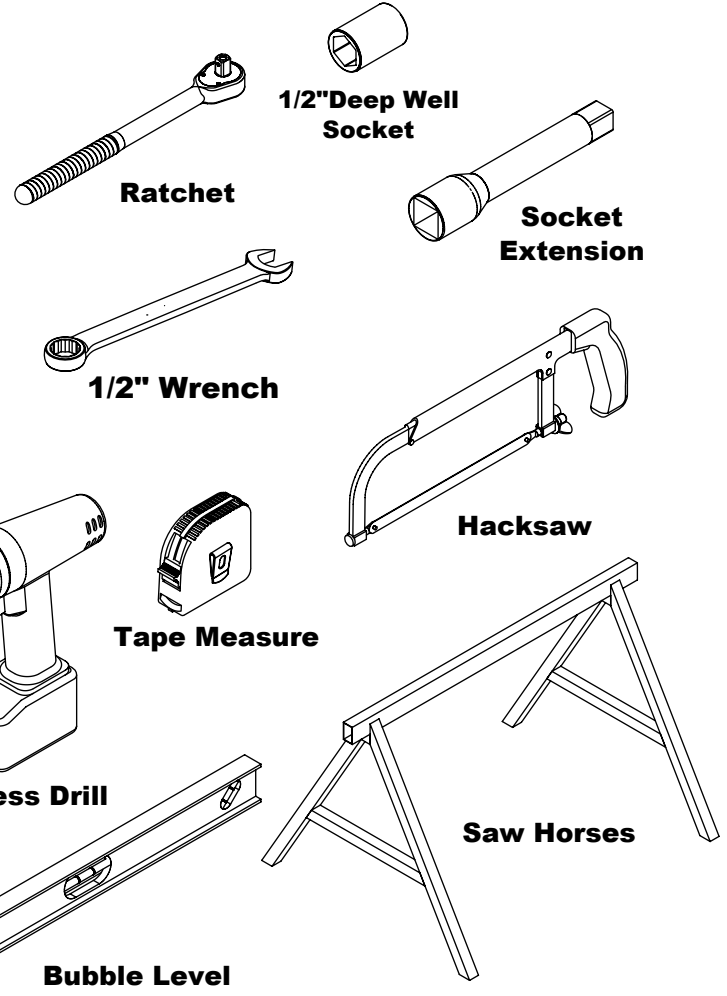

1.2 HARDWARE LIST

- 5/16x1-1/4 Carriage Bolt
- 5/16x3/4 Carriage Bolt
- 5/16x3-1/4 Hex Bolt
- 5/16x3/4 Flange Bolt
- 5/16 Selflock Nut
- 5/16 Jam Nut
- 5/16 Flat Washer
- 1/4x1 Self Tapping Screw
- #10-16 Self Tapping Screw
- Handrail Splice

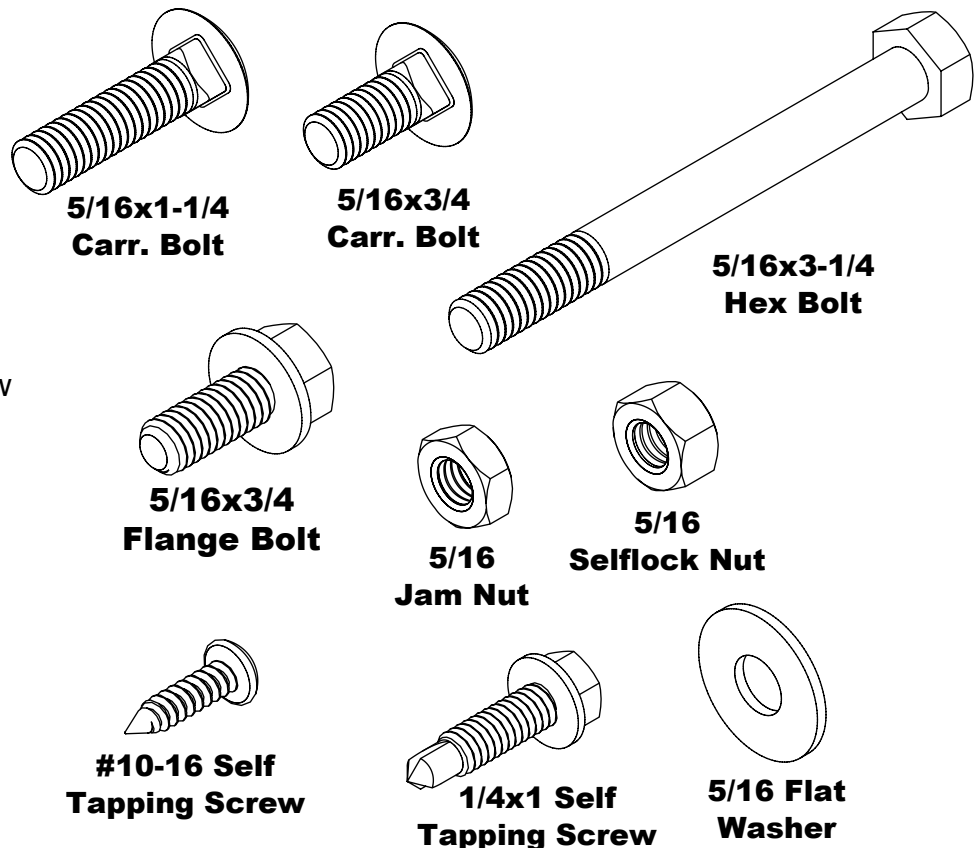

SECTION 2: RAMP & PLATFORM PARTS

2.1 STANDARD RAMP PARTS

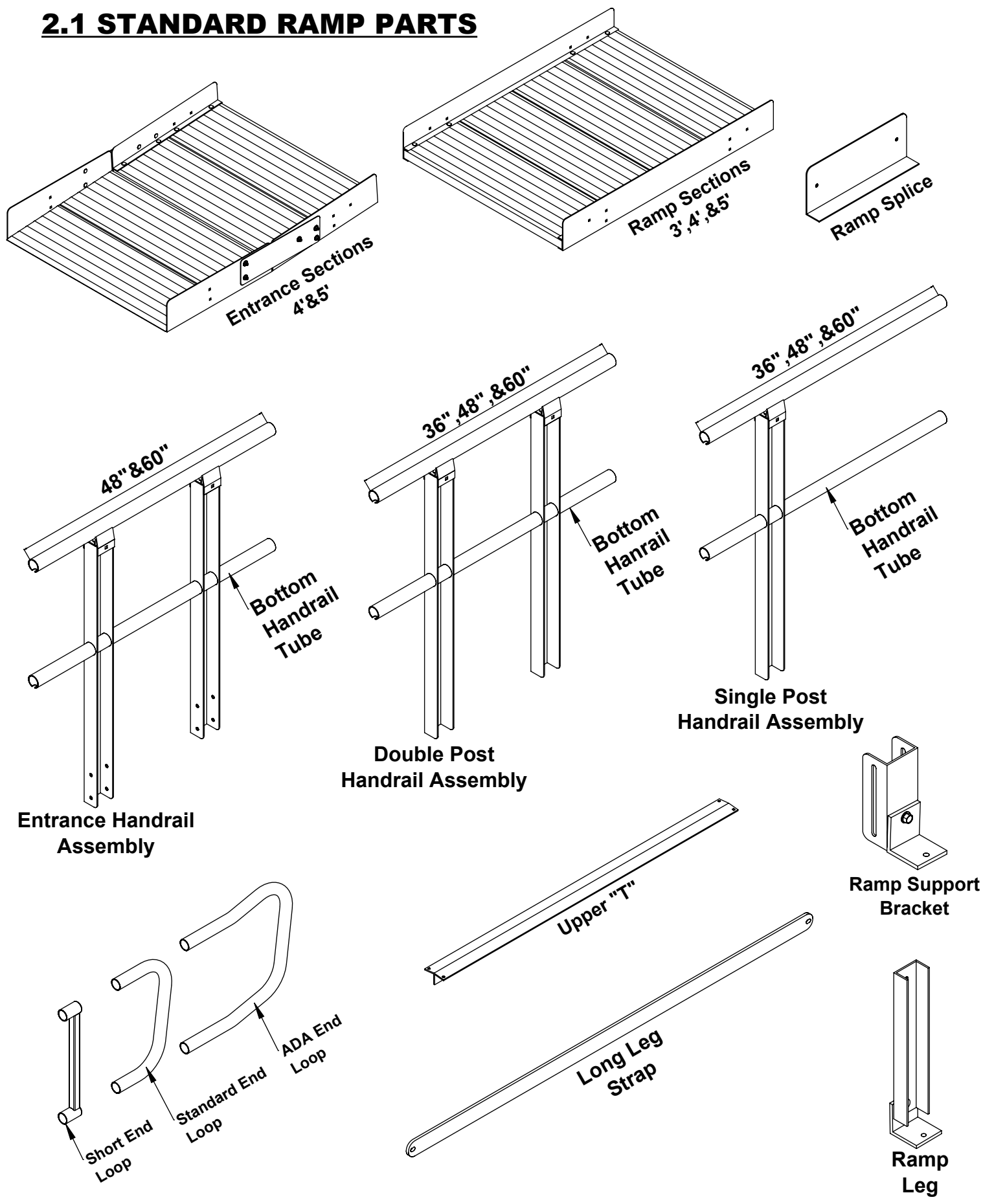

SECTION 2: RAMP & PLATFORM PARTS

2.2 STANDARD PLATFORM PARTS

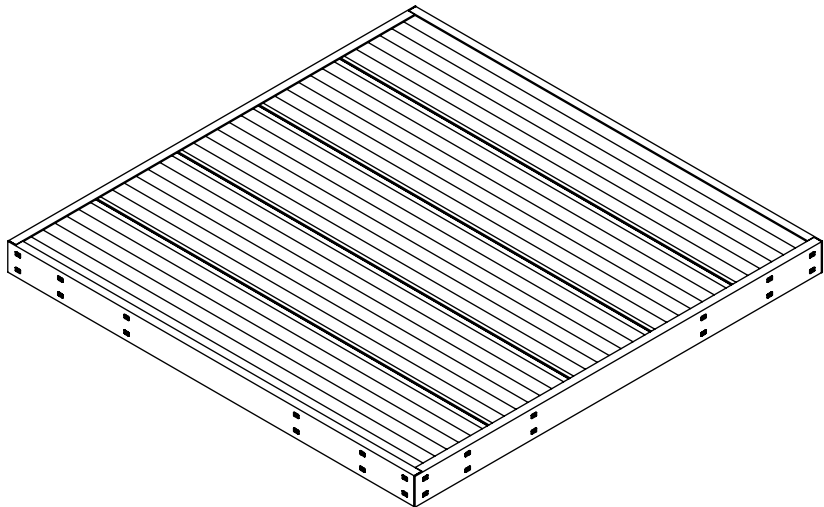

Platform Bases
4'x5' & 5'x5'

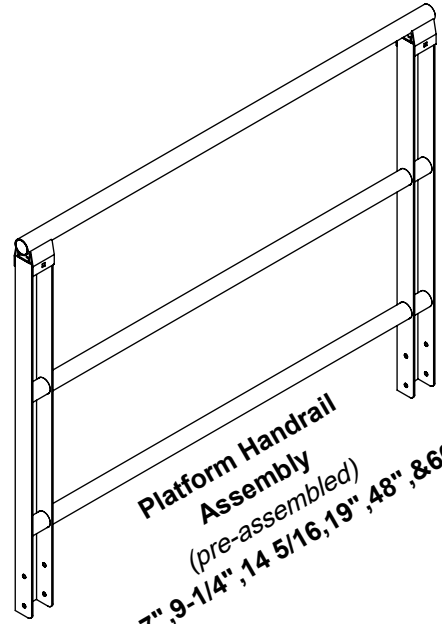

Platform Handrail Assembly
(pre-assembled)
3", 7", 9-1/4", 14 5/16", 19", 48", & 60"

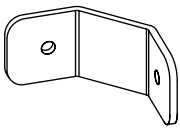

Post Corner Bracket

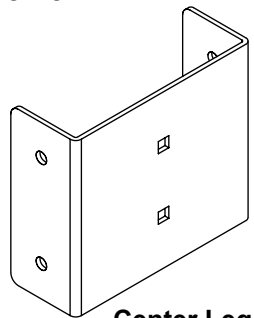

Center Leg Bracket

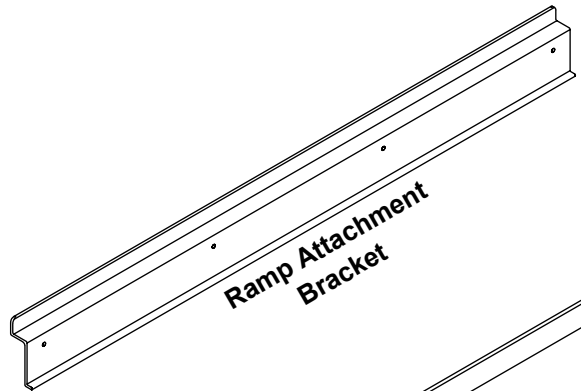

Ramp Attachment Bracket

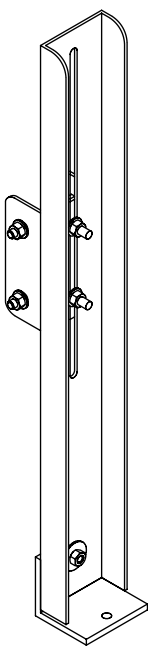

Platform Leg

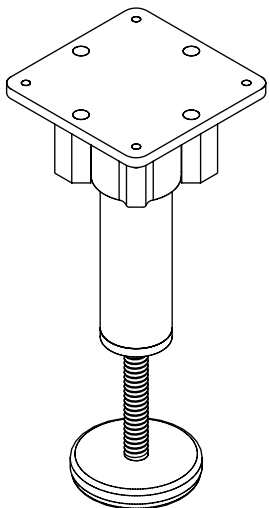

Platform Under-Support

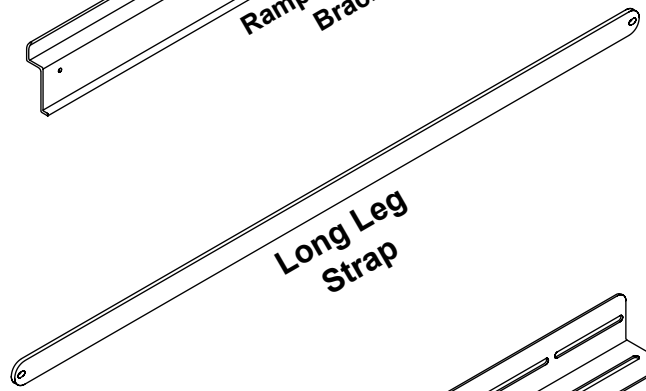

Long Leg Strap

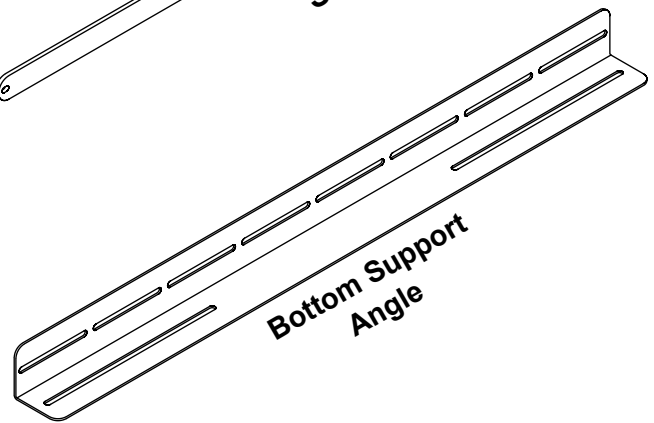

Bottom Support Angle

SECTION 2: RAMP & PLATFORM PARTS

2.3 STANDARD PLATFORM CONFIGURATIONS

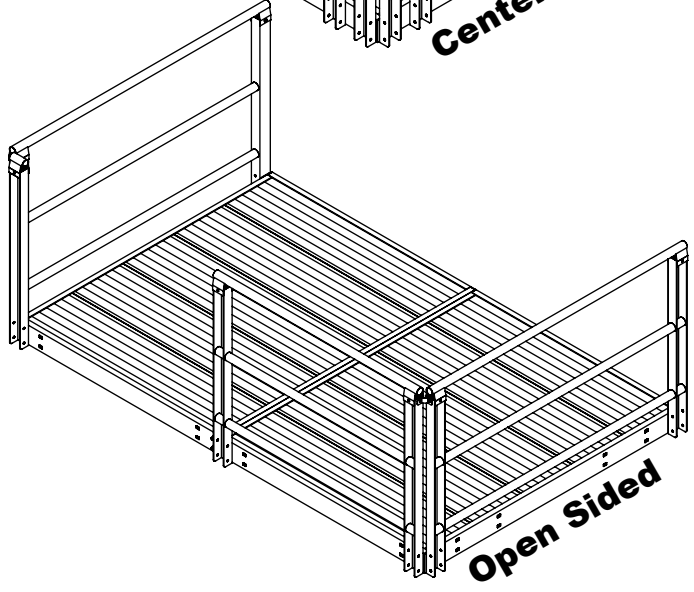
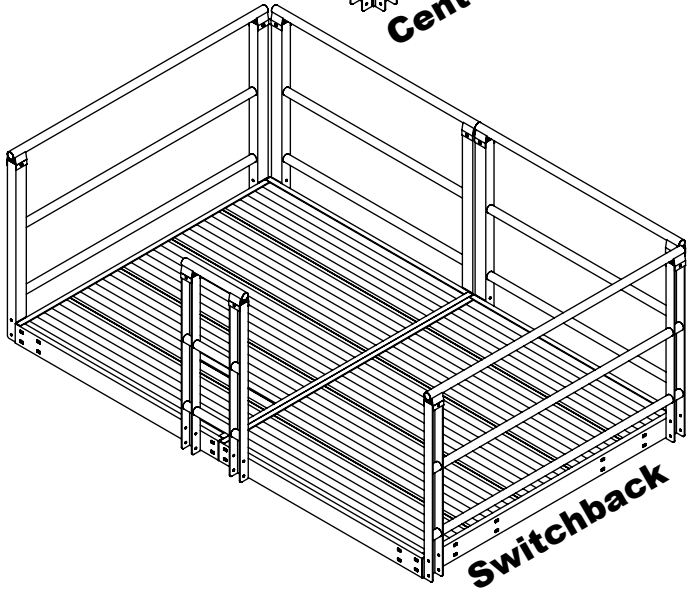
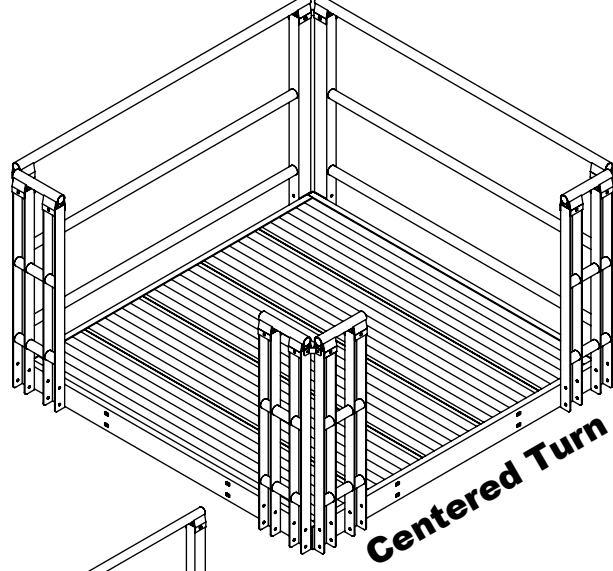
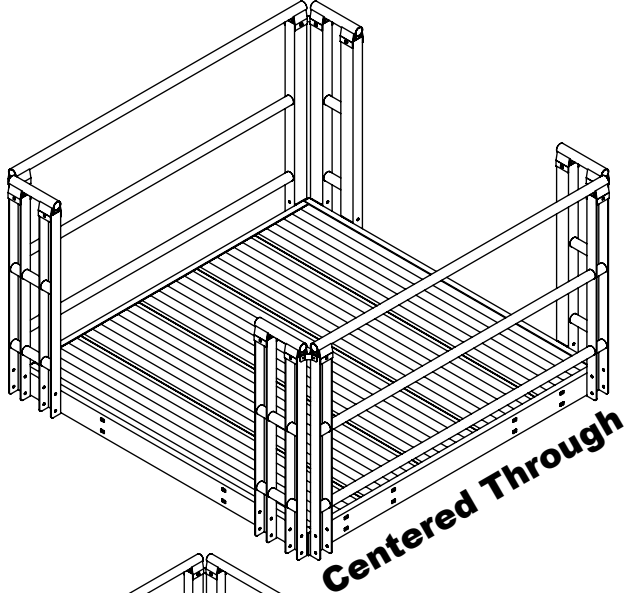
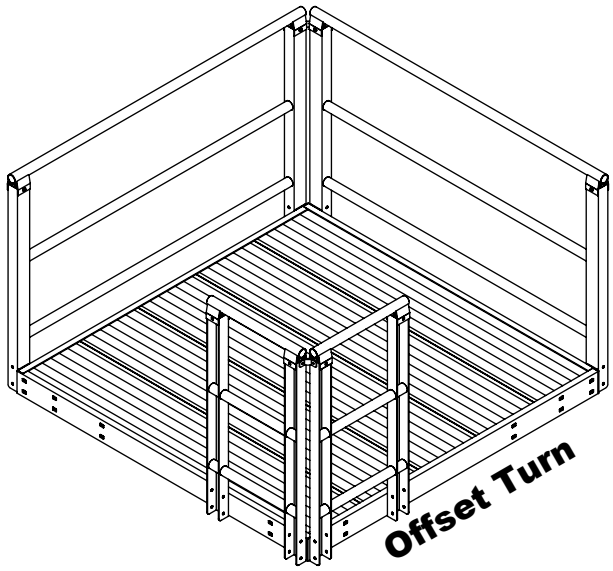
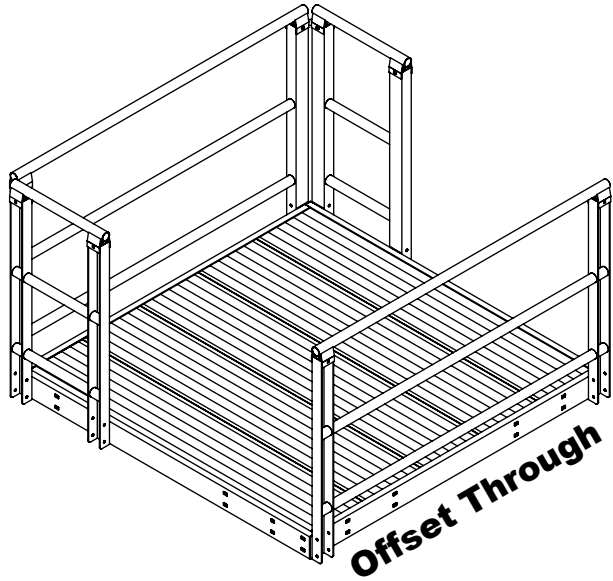

SECTION 2: RAMP & PLATFORM PARTS

2.4 OPTIONAL PARTS

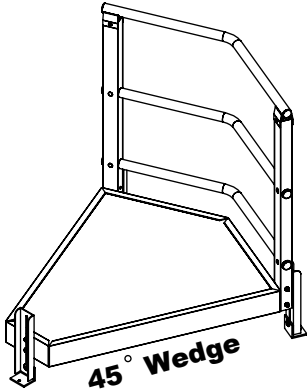

ANGLE WEDGES: 30°, 45°, & 60° Wedges are used when a platform is needed, but does not have the space required to use a platform or make a 90° turn.

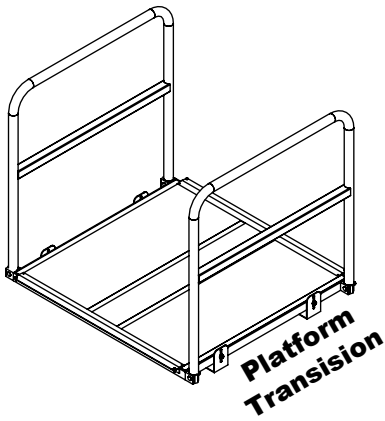

PLATFORM TRANSITIONS: Platform Transitions are used when the entrance/door off of the top platform requires a level bridge from the platform to door. Platform transitions are to only be used at minimal height, and always be level.

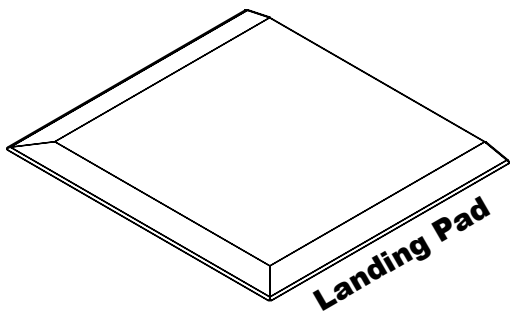

LANDING PADS: Landing pads are used when bottom ramp ending surface is not suitable for accessing the bottom ramp of a modular ramp system, it is not recommended to use this as the only anchor point for a bottom ramp.

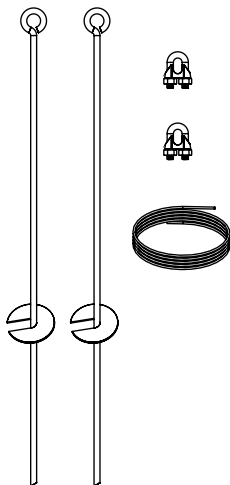

HURRICANE KIT: Hurricane Kits are used when required in applications where local building codes require that the modular ramp system be anchored to the ground.

Hurricane Kit

SECTION 3: PLATFORM ASSEMBLY

3.1 HANDRAIL TO PLATFORM ATTACHMENT

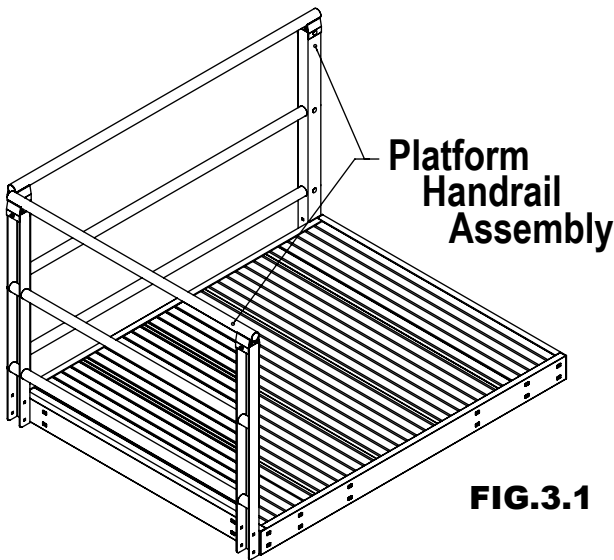

FIG.3.1

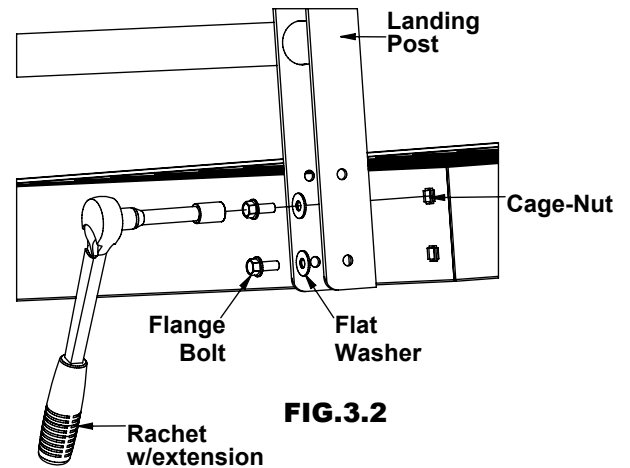

FIG.3.2

3.1 HANDRAIL TO PLATFORM ATTACHMENT: Align the holes at the bottom of handrail post with the pre-installed cage-nuts in the landing base. Place a 5/16x3/4 flange bolt through flat washer and slotted holes in landing post thread flange bolt into cage-nut, do not fully tighten bolts until each bolt has been started (Fig.3.2). Repeat this process at each post location. **NOTE:** Setting platform base on saw horses will make attaching handrail quicker and easier.

3.2 POST CORNER BRACKET INSTALL

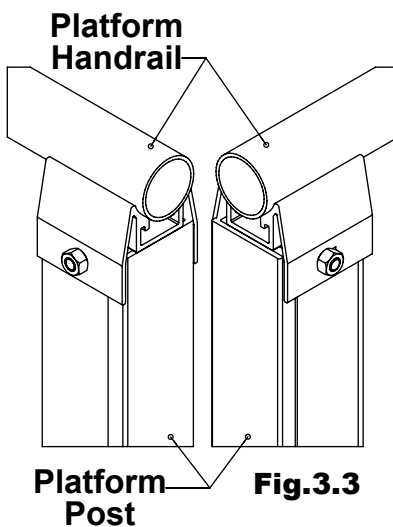

Fig.3.3

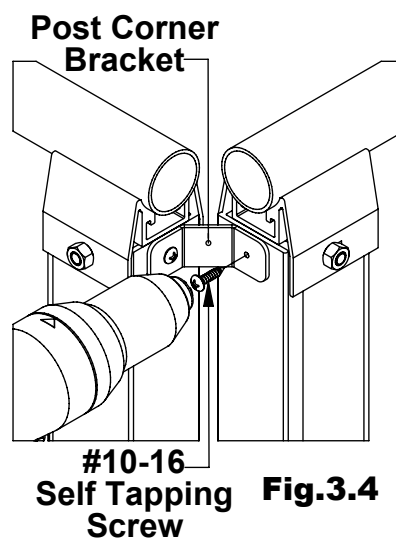

Fig.3.4

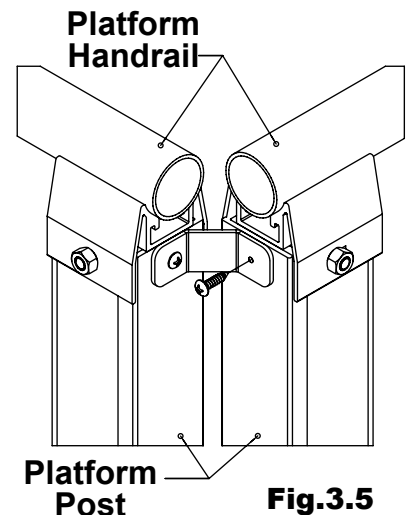

Fig.3.5

3.2 POST CORNER BRACKET INSTALL: Once all handrail has been attached to platform the post corner brackets will need to be installed in all corners where handrail meet (Fig.3.3). Place bracket in the corner with the pilot hole in the bracket centered on the platform post, and the edge flush up against the handrail bracket attached to the platform post. Using a self-tapping screw and cordless drill attach the post corner bracket to platform post (Fig.3.4). **NOTE:** If corners do not line up perfectly it may be necessary to force the second post into the proper position.

SECTION 3: PLATFORM ASSEMBLY

3.3 PLATFORM LEG ATTACHMENT

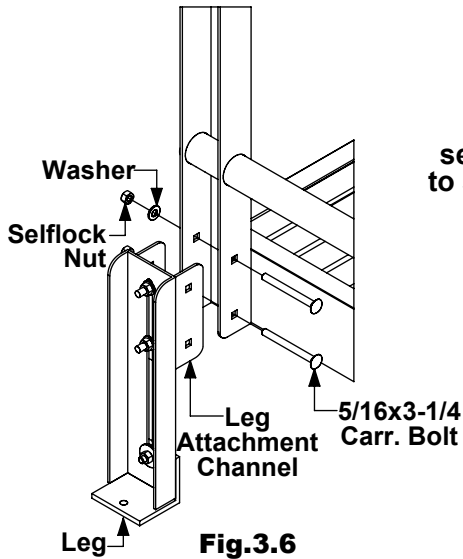

Fig.3.6

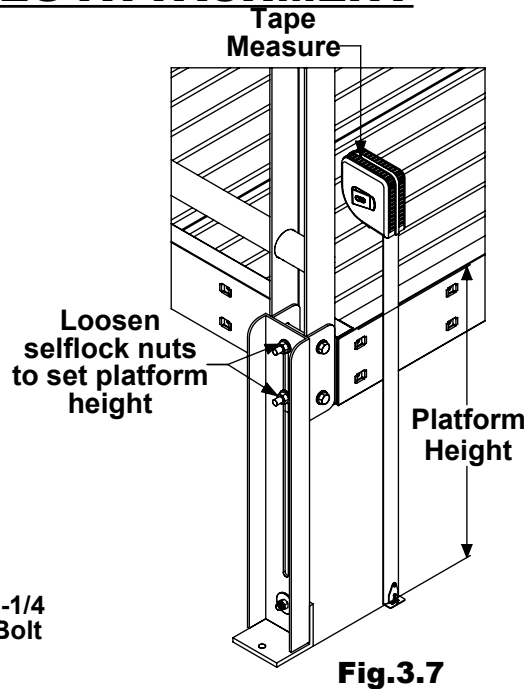

Fig.3.7

3.3 PLATFORM LEG ATTACHMENT:

Attach legs to platform by placing the leg attachment channel over the handrail post with one edge of the attachment channel over the handrail post with one edge of the attachment channel on the inside of the handrail post and one to the outside of the handrail post. Align the holes in the handrail post and the leg attach channel, place a 5/16x3-1/4 hex bolts through all and fasten with a flat washer and selflock nut (Fig.3.6). To adjust the leg height, loosen the selflock nuts in the center of the leg channel and set landing height, retighten the selflock nuts (Fig.3.7). **NOTE:** When adjusting platform height pressure may need to be applied to leg when re-tightening selflock nuts to carriage bolts in place.

3.4 PLATFORM UNDER-SUPPORT ATTACHMENT

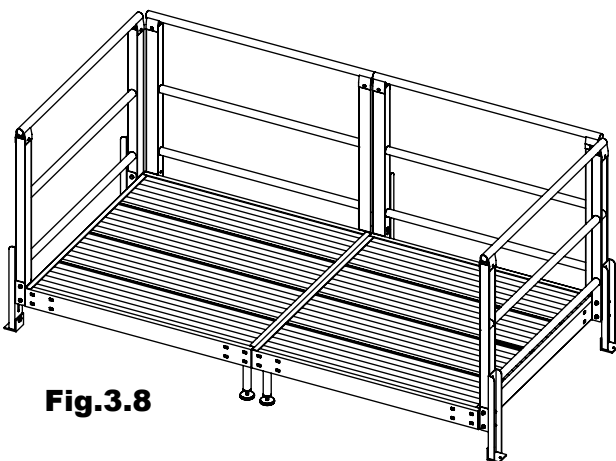

Fig.3.8

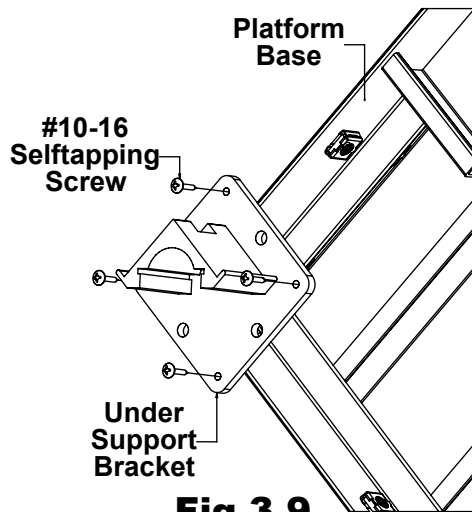

Fig.3.9

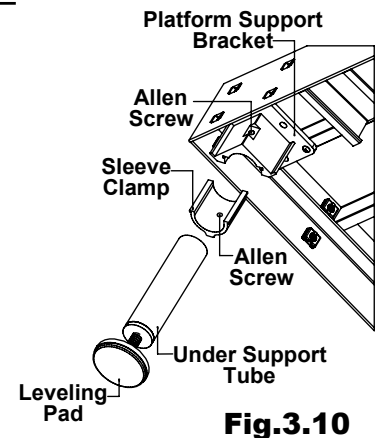

Fig.3.10

3.4 PLATFORM UNDER SUPPORT ATTACHMENT: Locate corners of platform that will require a platform under support kit (Fig.3.8). Place under support bracket flush in the corner of platform base, attach with four #10-16 self-tapping screws (Fig.3.9). Slip the sleeve clamp into the under support bracket, insert under support tube (Fig.3.10). Using a 5/32 allen wrench tighten set screw all of the way. The leveling pad can be used to make minor height adjustments; however, if major adjustments are necessary, the under support tube will need to be cut down.

SECTION 3: PLATFORM ASSEMBLY

3.5 MULTIPLE PLATFORM BASE CONNECTION

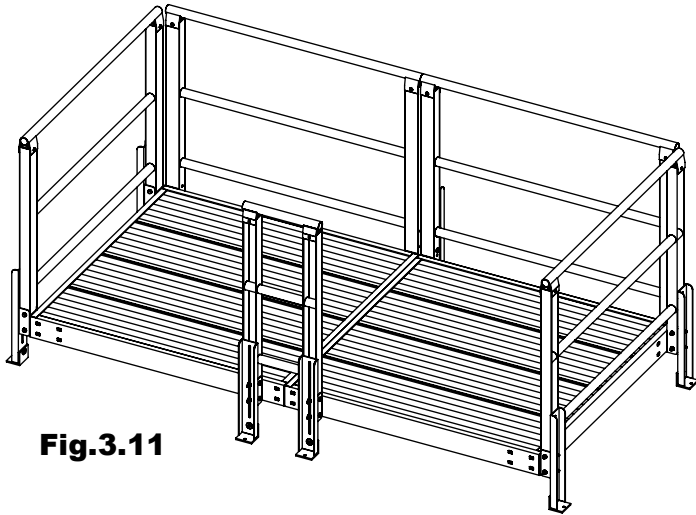

Fig. 3.11

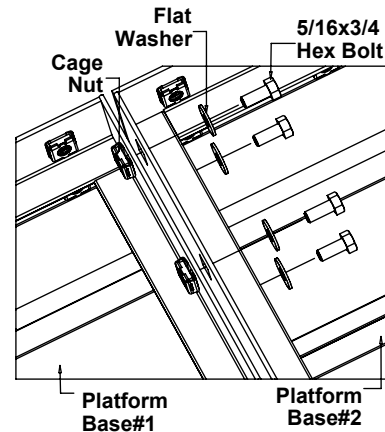

Fig. 3.12

3.5 MULTIPLE PLATFORM BASE CONNECTION: To connect platform bases remove cage-nuts from one of the platforms at the seam. Place a 5/16x3/4 hex bolt with washer through the square hole on the inside of the landing channel and thread hex bolt into the aligning cage-nut on the opposite platform (Fig. 3.12). Depending on the rise of the platform this connection can be made before or after attaching the handrail and legs. It is recommended that platform applications with a rise greater than 24" be connected after the handrail and legs have been installed.

3.6 MULTIPLE PLATFORM BASE ASSEMBLY

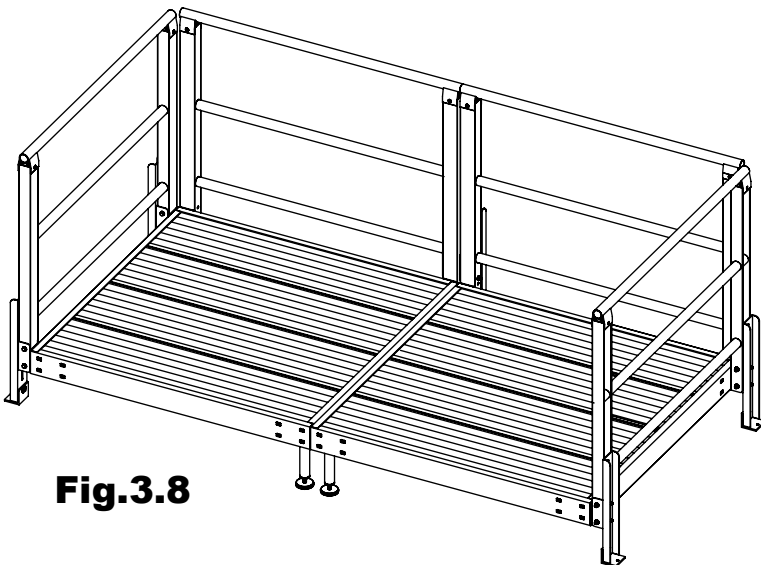

Fig. 3.8

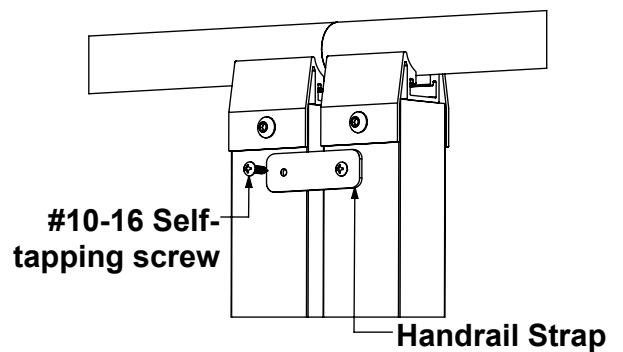

Fig. 3.14

3.6 MULTIPLE PLATFORM ASSEMBLY: With both platform bases completely assembled and connected at the seam, (Fig. 3.13) attach landing handrail strap to the landing post. Position and attach landing handrail strap on center with landing post just below the top handrail using a #10-16 self-tapping screw (Fig. 3.14).

SECTION 3: PLATFORM ASSEMBLY

3.7.1 PLATFORM LONG LEG SUPPORT (ANGLE)

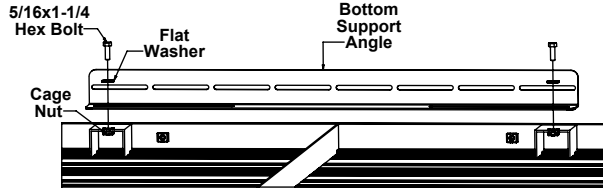

Fig.3.17

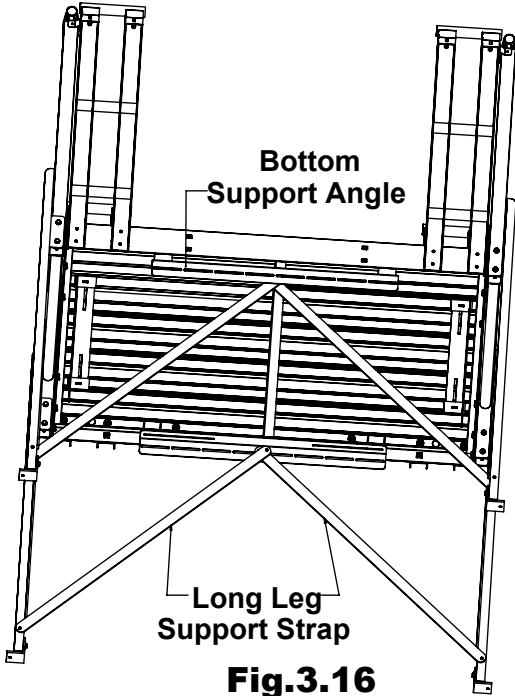

Fig.3.16

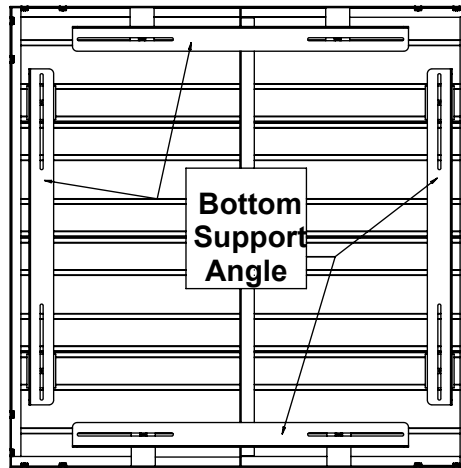

Fig.3.18

3.7.1 PLATFORM LONG LEG SUPPORT (ANGLE):

Platform applications with a rise of 27" or greater will require long leg supports. Bottom support angles will need to be attached to platform base before assembling platform. Turn platform base on its top and attach bottom support angles on center to all four sides of platform. To attach align the two long slotted holes with cage-nuts on the bottom side of platform and fasten with 5/16x1-1/4 hex bolts, and flat washers (Fig.3.17). Attach legs and handrail to platform before next step.

3.7.2 PLATFORM LONG LEG SUPPORT (STRAP)

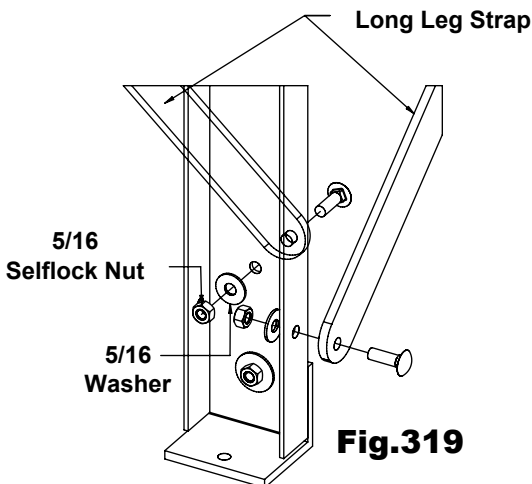

Fig.3.19

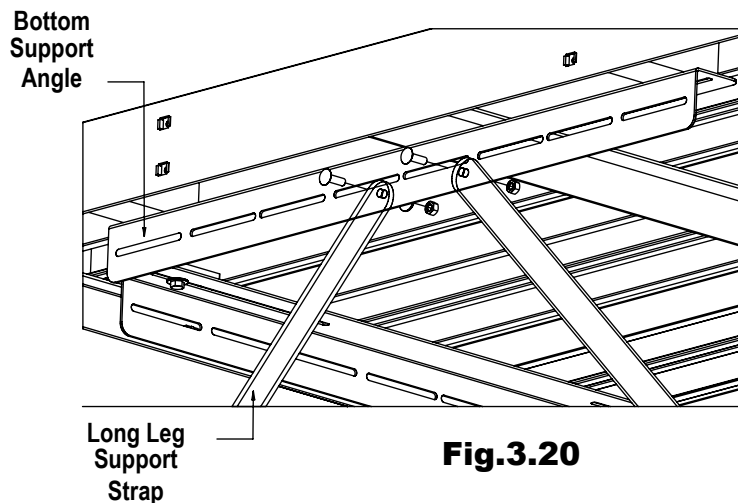
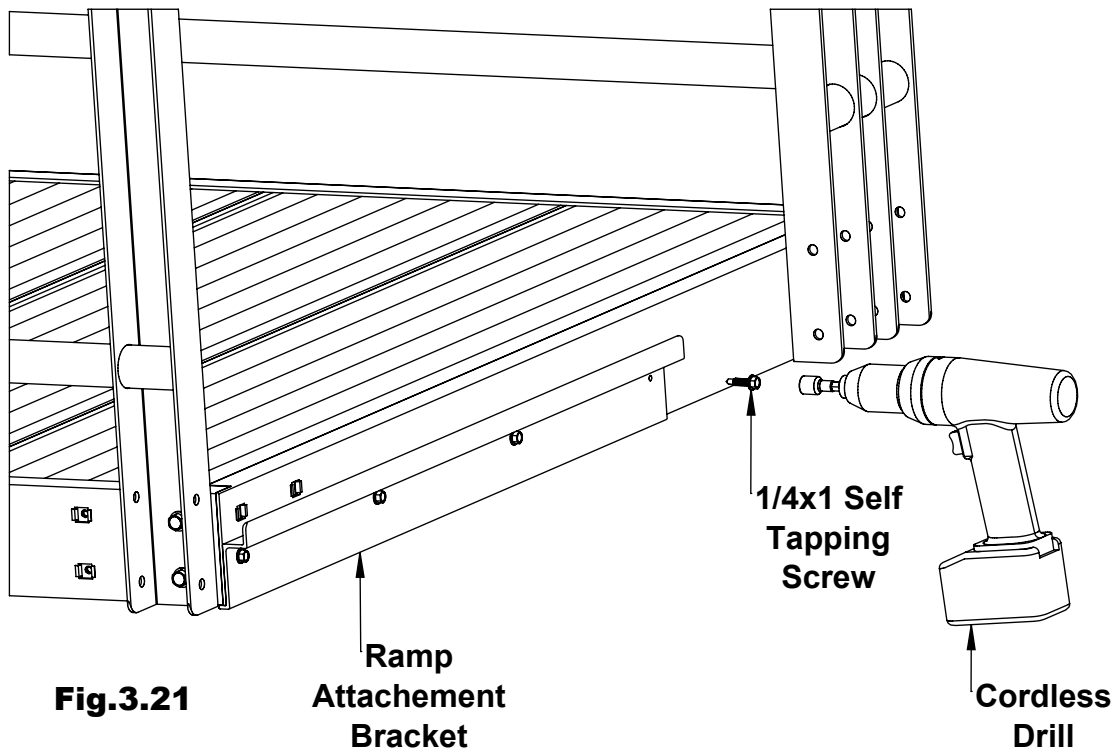

Fig.3.20

3.7.2 PLATFORM LONG LEG SUPPORT (STRAP): Once platform assembly has been completed the long leg support straps can now be attached. First attach support strap to leg channel using the holes in the leg channel fasten with 5/16x1 carriage bolt, washer, and selflock nut (Fig.3.19). Next select the slotted hole in the bottom support angle best suited for platform application and fasten with a 5/16x1 carriage bolt, washer, and selflock nut. (Fig.3.20). **NOTE:** Some applications may require drilling a hole in the leg channel to attach the long leg support straps.

SECTION 3: PLATFORM ASSEMBLY

3.8 Ramp Attachment Bracket Installation



3.8 RAMP ATTACHMENT BRACKET INSTALLATION: Determine ramp opening locations. Attach Ramp Attachment Bracket to landing base on center with ramp opening using $\frac{1}{4}$ x 1 self tapping screws (**Fig.3.21**). **NOTE:** The Ramp Attachment Bracket is not designed to hold the weight of the ramp, make sure ramp is properly supported at both ends by the ramp legs.

SECTION 4: RAMP ASSEMBLY

4.1 RAMP SECTION ASSEMBLY (TOP RAMPS)

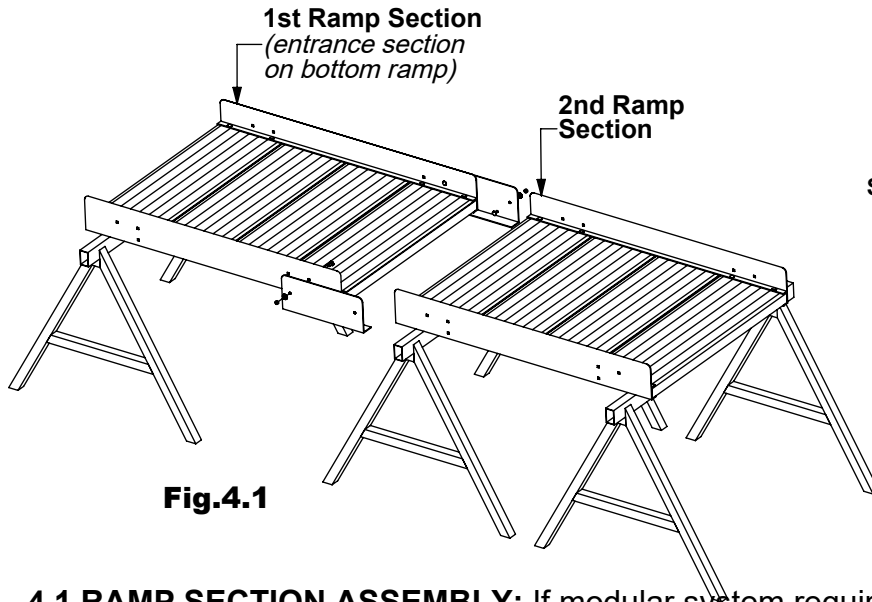

Fig.4.1

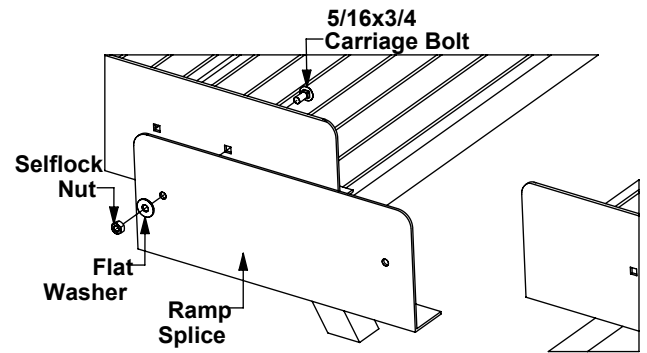

Fig.4.2

4.1 RAMP SECTION ASSEMBLY: If modular system requires platform, assemble platforms first and set in place before assembling ramp sections. Start by set the first ramp section on sawhorses (*shortest ramp section Fig.4.1*). If assembling bottom ramp run start with the entrance section. Attach a ramp splice to each side of the first section of ramp using the square holes in the ramp frame rail closest to the end of ramp section. Place ramp splice over the ramp frame rail and align the holes of the ramp splice and ramp frame rail (**Fig.4.2**). With the head of the carriage bolt to the inside of ramp section fasten with flat washer, and selflock nut. Repeat this process until the entire ramp run is complete.

4.2 RAMP POST ATTACHMENT

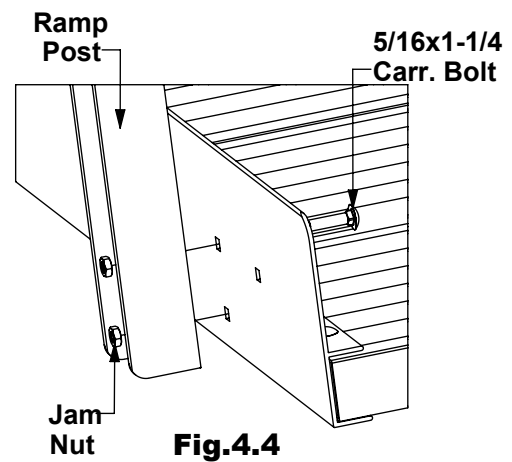
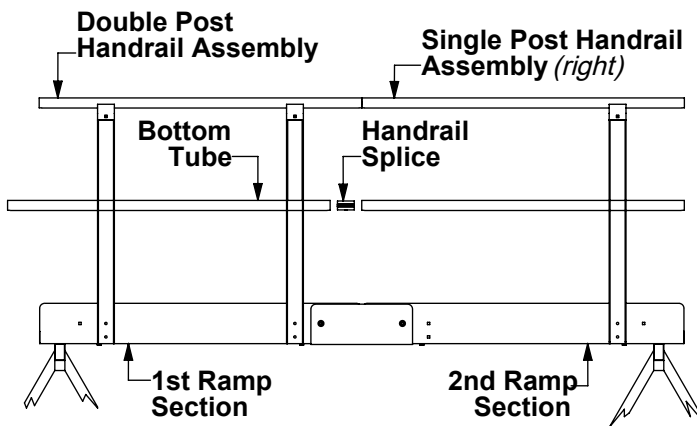
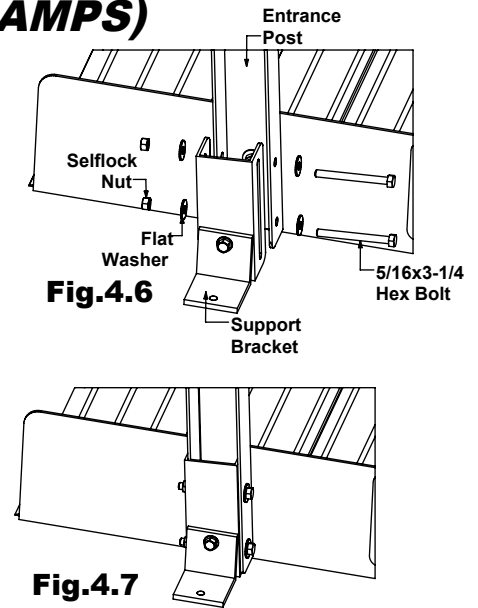
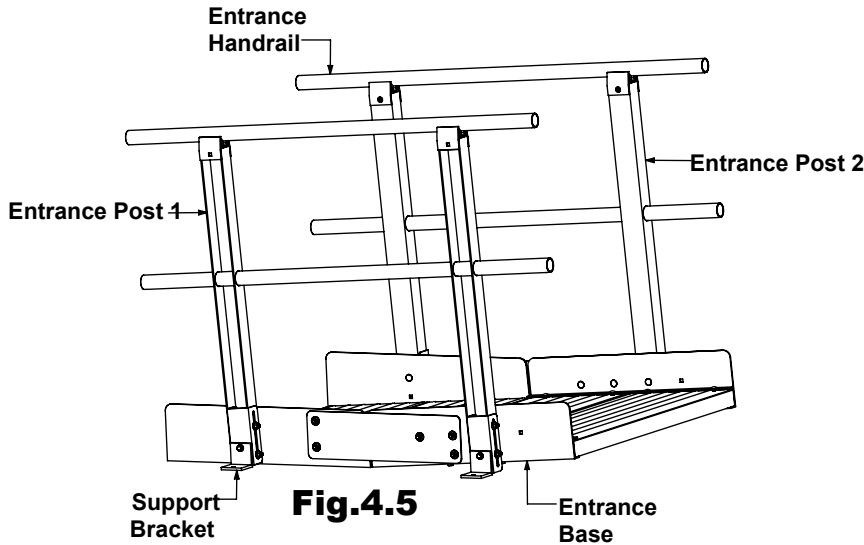

Fig.4.4

4.2 RAMP POST ATTACHMENT: After all of the ramp sections of the ramp run have been joined together attach the handrail assemblies. Start by laying the handrail assemblies along side of the ramp run. Starting with the shortest ramp section attach the double post handrail. To attach align the two round holes in the post with the two square holes in the ramp frame rail and fasten with carriage bolts and jam nuts at each post location (**Fig.4.4**). Next insert a handrail splice inside of the double post top handrail tube before attaching a single post handrail assembly to the next section of ramp (**Fig.4.9, pg. 17**). Slide top handrail tube of single post handrail assembly over handrail splice and attach single post handrail to the next section of ramp. Repeat this step for each section of ramp. Once all of the handrail posts have been attached to ramp run slide the bottom handrail tube through the holes in the ramp post, with bottom tubes even with top tubes tighten handrail splice (**Fig.4.8, pg. 17**).

SECTION 4: RAMP ASSEMBLY

4.2.1 ENTRANCE ASSEMBLY (BOTTOM RAMPS)



4.2.1 ENTRANCE ASSEMBLY: Locate left and right entrance handrail assemblies attach handrail assemblies to entrance base with the short post located closest to the ground. Fasten handrail as shown in **Section 4.2, pg.16**. Next attach support brackets to entrance post (**Fig.4.6**). To attach support brackets place support bracket channel inside of post channel using the slotted holes in the support bracket and the round holes in the post fasten with 5/16x3-1/4 hex bolts, washers, and selflock nuts leaving hardware loose enough for final adjustments. Position ramp in the final resting location, adjust support brackets so angles are flat on the resting surface and anchor down using the holes in the angle. Anchoring ramp to final resting surface at this location will provide the strength needed to the entrance post.

4.3 HANDRAIL SPLICE INSTALLATION

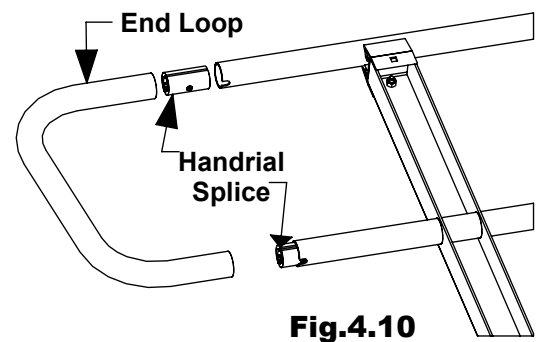
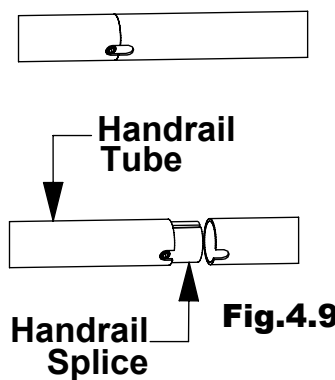
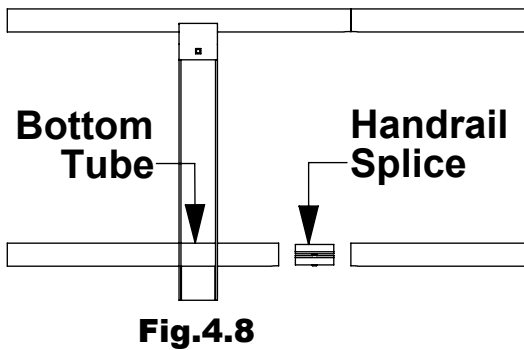

4.3 HANDRAIL SPLICE INSTALLATION: A handrail splice will be used at each handrail tube transition to connect the handrail tubes together giving the handrail the look and feel of one continuous tube. With the handrail splice in place, position set screw inside of notch on the bottom side of the handrail tube (**Fig.4.9**) pull tubes together and tighten the set screw using a 5/32 allen wrench.

SECTION 4: RAMP ASSEMBLY

4.4 RAMP TO LANDING ATTACHMENT

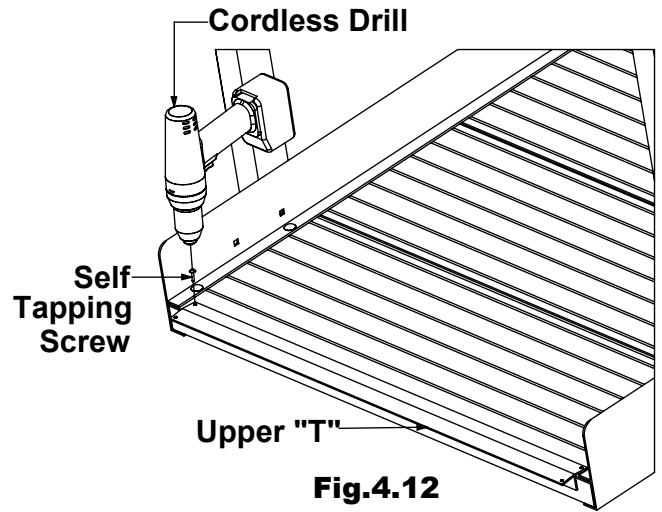
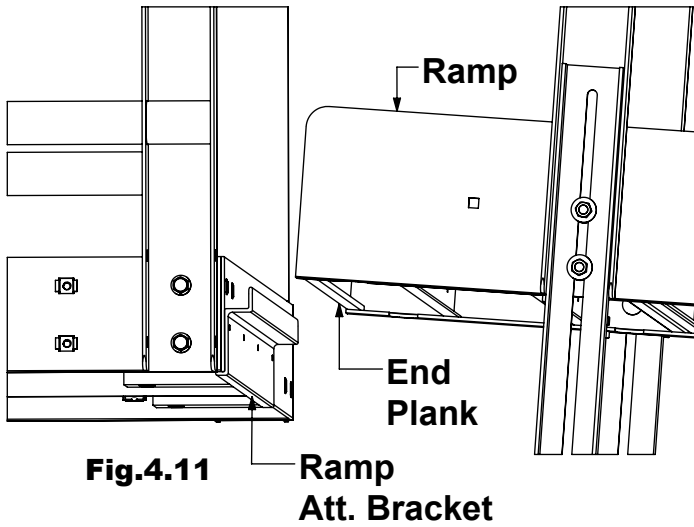

4.4 RAMP TO LANDING ATTACHMENT: Before attaching ramp to platform the ramp attachment clip must be installed (*Section 3.8 Fig.3.21 pg.15*). Place the end plank of ramp over the ramp attachment clip (**Fig.4.11**). Place upper "T" between ramp and platform to fill the gap. Secure in place with self-tapping screws in all four corners. If ramp ends on a preexisting platform/porch attach upper "T" to end of ramp and secure to preexisting platform/porch. **NOTE:** The ramp attachment bracket and upper "T" are not designed to hold the load of the ramp, ramp legs must be installed before ramp is ready to use.

4.5 LEG ATTACHMENT & ADJUSTMENT

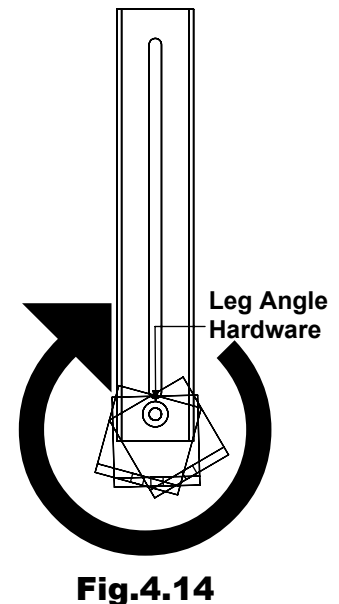
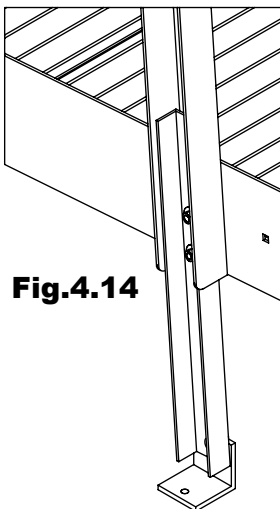
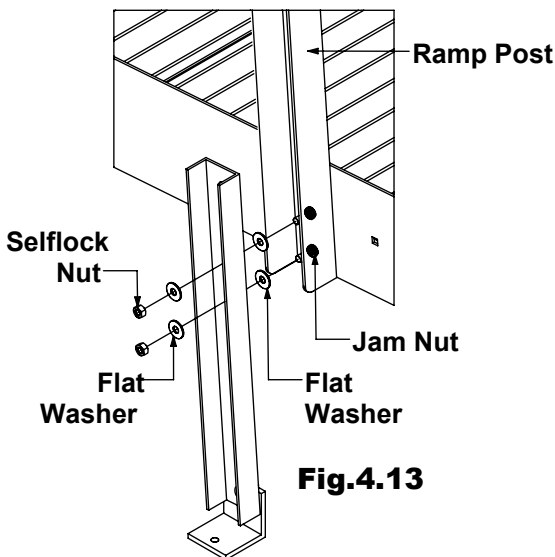

4.5 LEG ATTACHMENT & ADJUSTMENT: With the ramp run completely assembled and in its final resting location the legs can now be attached and adjusted. Place a flat washer over the carriage bolt, and jam nut used to fasten the ramp post to the ramp base. Place leg inside of ramp channel with both carriage bolts through the slotted hole in the ramp leg, fasten with a flat washer and selflock nut (**Fig.4.13**). Loosen leg angle hardware, and slide leg down. Make sure the leg angle is flat on the resting surface making solid contact, re-tighten all leg hardware.

SECTION 4: RAMP ASSEMBLY

4.6 LONG LEG SUPPORTS (*RAMPS*)

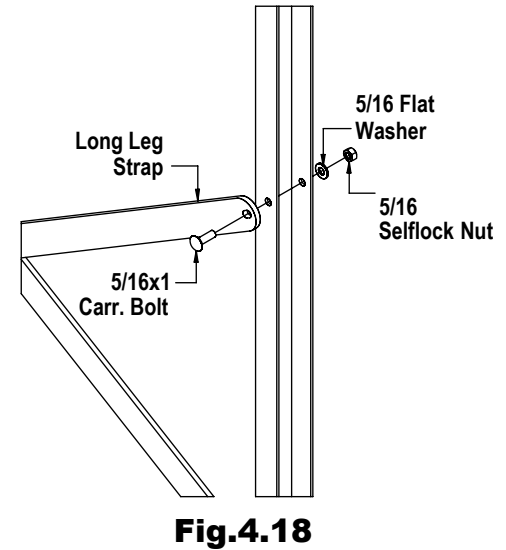
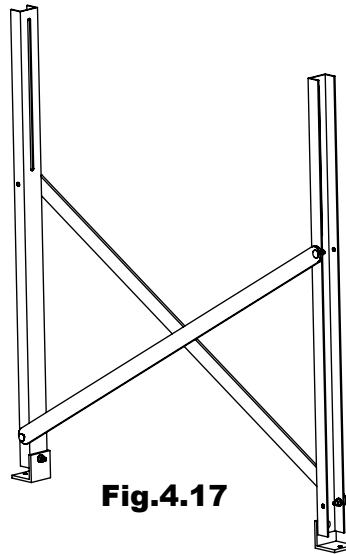
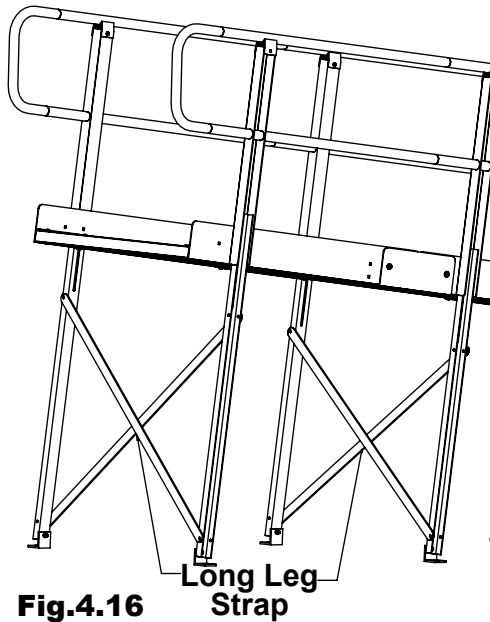

4.6 LONG LEG SUPPORTS (*RAMPS*): Long Leg Supports are required on any ramp with a rise of 27" or greater. Two leg brace straps will be required at each location requiring long leg supports. Attach the first leg brace strap to the leg channel, using the slotted hole at the end of the leg brace strap and the round hole punched in the leg channel, run a carriage bolt through both and fasten with washer and self locking nut on the inside of the leg channel (**Fig.4.18**). Finger tighten only, and attach the next strap on the other side of the ramp at the opposite end of the leg. Once hardware has been installed at both ends of the leg brace strap tighten hardware all of the way down (**Fig.4.17**). Repeat these steps on the other side of the legs running the straps the opposite direction so that the leg brace straps form an X between the ramp legs.

SECTION 5: OPTIONAL PARTS

5.1 HURRICANE TIE DOWN KIT (*Platforms*)

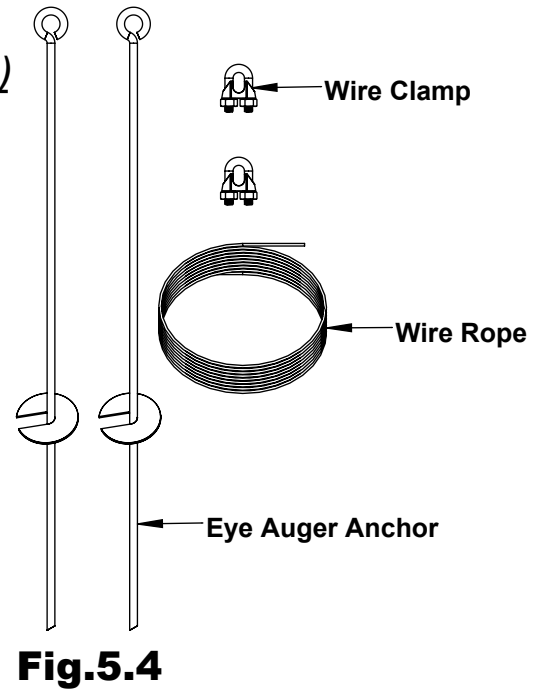
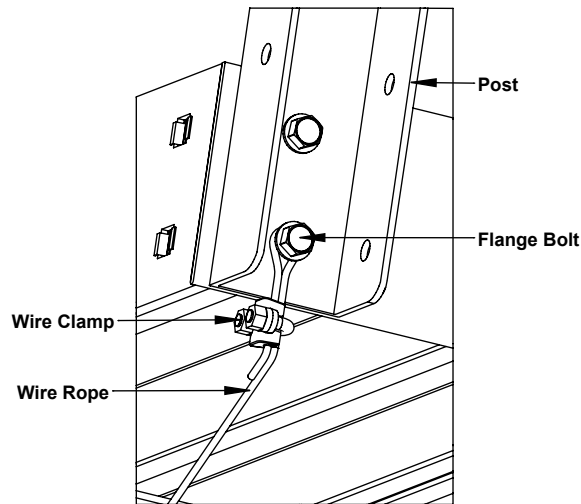
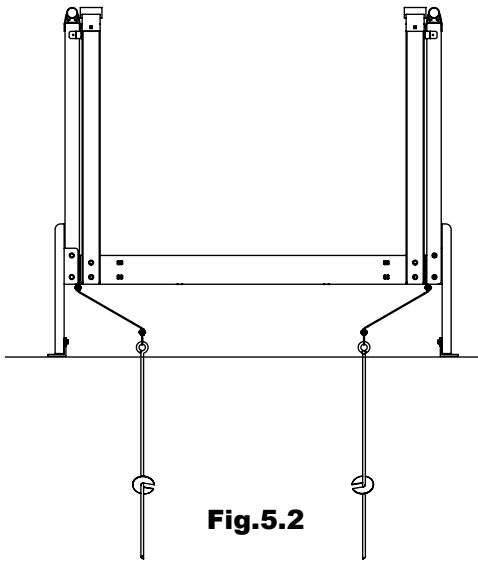

5.1 HURRICANE TIE DOWN KIT (LANDINGS): Field conditions will determine the location of the tie downs. The PVI Modular Ramp System will have to be fully assembled and placed in its final resting position to determine exact locations of the eye auger anchors; it may be necessary to temporarily reposition components to install the anchors. Anchors will need to be installed at all four corners of the platform. Screw augers vertically into the ground leaving only the eye of the auger exposed (**Fig.5.2**). At corner post location or nearest loosen the lowest flange bolt, loop wire around flange bolt and clamp with wire clamp re-tighten flange bolt (**Fig.5.3**). Place other end of wire through the auger eye cinch tight and clamp with wire clamp. Cut off any excess rope and tape ends with electrical tape to ensure that the wire rope will not fray.

!!!WARNING!!! PRIOR TO INSTALLING THE ANCHORS INTO THE GROUND, ENSURE THAT ANY UNDERGROUND ELECTRICAL CONDUCTORS, NATURAL GAS LINES, WATER/DRAIN LINES AND/OR OTHER INTERFERENCES ARE LOCATED AND WILL NOT HINDER THE INSTALLATION.

!!!WARNING!!! DO NOT USE CONCRETE ANCHORS IN ASPHALT. ASPHALT IS NOT CONSIDERED A SUITABLE ANCHORING SURFACE. IF INSTALLING ON ASPHALT, HOLES WILL HAVE TO BE MADE IN ASPHALT, AND THE ANCHOR AUGER INSTALLED INTO THE GROUND.

!!!WARNING!!! REGULARLY INSPECT INSTALLATION FOR ANY LOOSE WIRE, FASTENERS, AUGER ANCHORS, ECT.

SECTION 5: OPTIONAL PARTS

5.2 HURRICANE TIE DOWN KIT (Ramps)

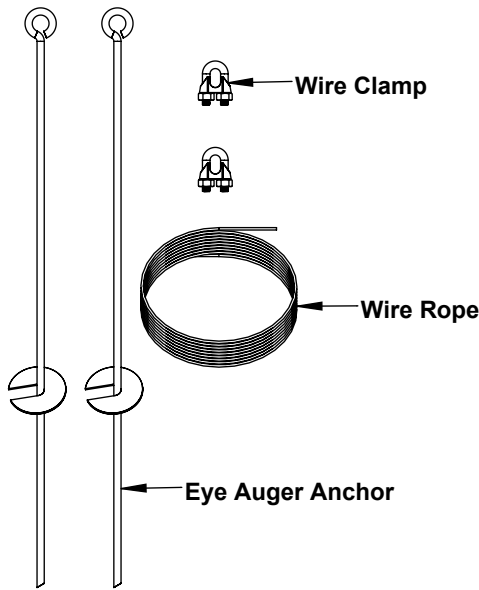

Fig.5.4

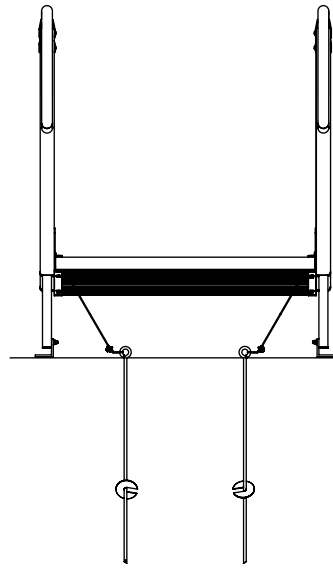

Fig.5.5

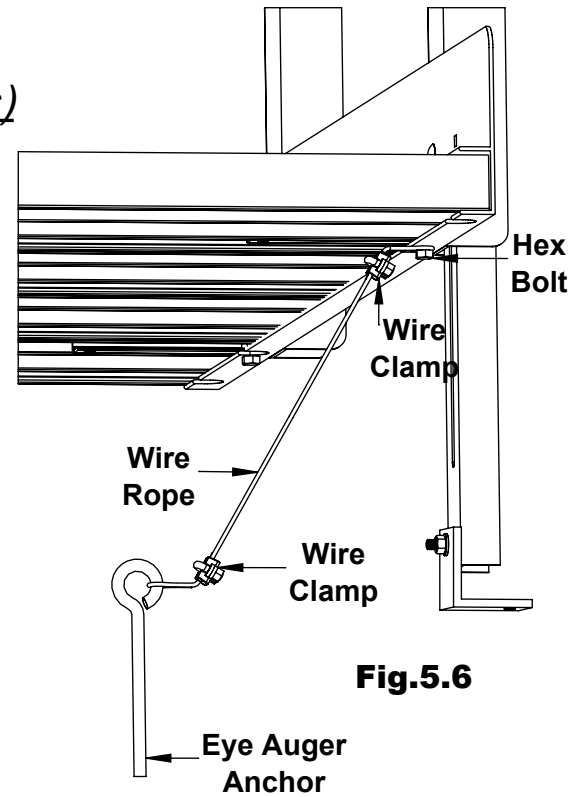
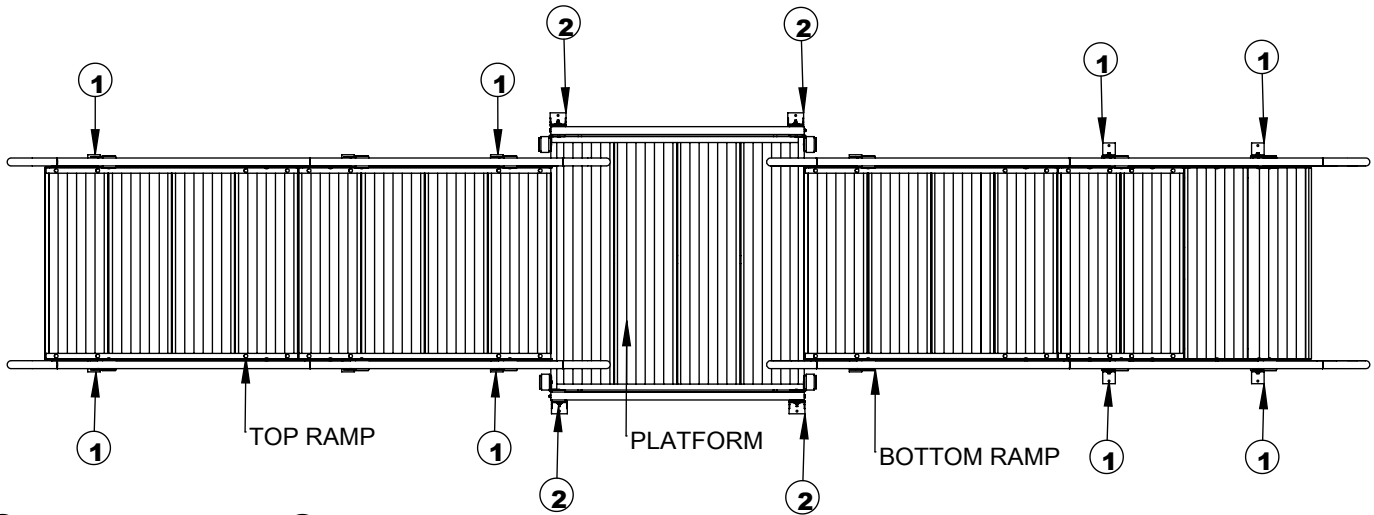

Fig.5.6

5.2 HURRICANE TIE DOWN KIT (RAMPS): Ramp sections require a tie down on each side of the ramp section at the lowest post location at each ramp section. Locate hex bolt on bottom side of ramp and loosen, loop wire around hex bolt and clamp with wire clamp re-tighten hex bolt. Screw auger vertically into the ground leaving only the eye of the auger exposed (Fig.5.5). Place other end of wire through the auger eye cinch tight and clamp with wire clamp (Fig.5.6). Cut off any excess rope and tape ends with electrical tape to ensure that the wire rope will not fray.



① RAMP LOCATIONS ② PLATFORM LOCATIONS **Fig.5.7**

!!!WARNING!!! PRIOR TO INSTALLING THE ANCHORS INTO THE GROUND, ENSURE THAT ANY UNDERGROUND ELECTRICAL CONDUCTORS, NATURAL GAS LINES, WATER/DRAIN LINES AND/OR OTHER INTERFERENCES ARE LOCATED AND WILL NOT HINDER THE INSTALLATION.

!!!WARNING!!! DO NOT USE CONCRETE ANCHORS IN ASPHALT. ASPHALT IS NOT CONSIDERED A SUITABLE ANCHORING SURFACE. IF INSTALLING ON ASPHALT, HOLES WILL HAVE TO BE MADE IN ASPHALT, AND THE ANCHOR AUGER INSTALLED INTO THE GROUND.

!!!WARNING!!! REGULARLY INSPECT INSTALLATION FOR ANY LOOSE WIRE, FASTENERS, AUGER ANCHORS, ECT.

SECTION 5: OPTIONAL PARTS

5.3 RAMP GATE

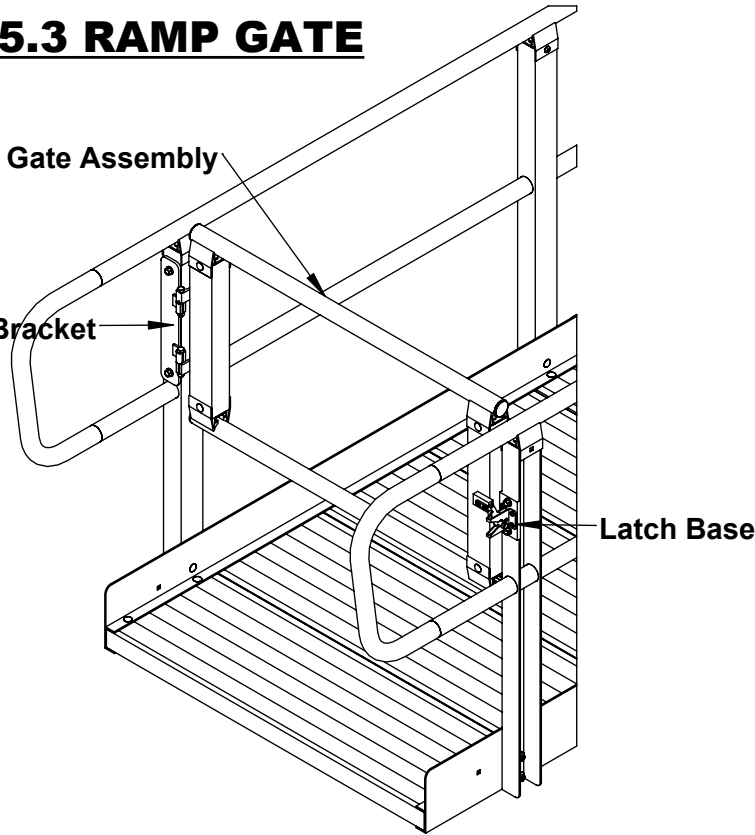

Fig.5.8

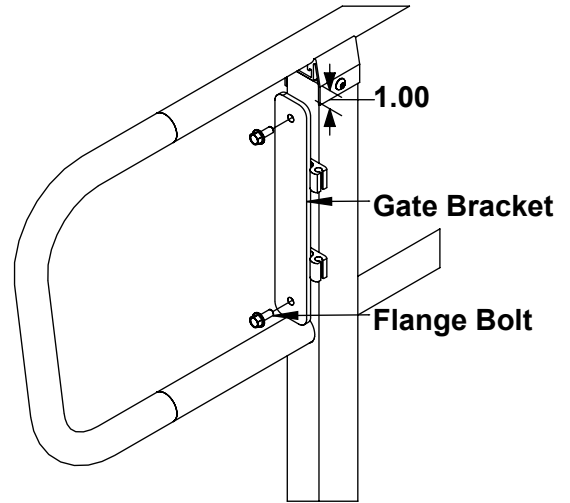

Fig.5.9

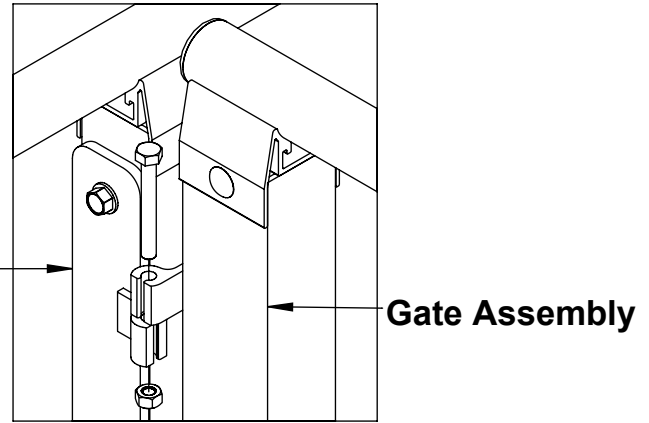

Fig.5.10

5.3 GATE ASSEMBLY: Place gate bracket 1.00" down and flush with edge of post (**Fig.5.9**). Mark location of holes and drill holes for 5/16" hardware. Attach with 5/16x3/4 Flange bolts, flat washers, and selflock nuts. Fasten gate assembly to bracket with 5/16x2½ hex bolts and selflock nuts (**Fig.5.10**) gate should swing freely do not over tighten hardware. Place latch with base on post approximately 5" down and flush with edge of post (**Fig.5.11**). Swing gate closed to make sure the latch rod engages the latch, it may be necessary to adjust latch up or down to properly align with latch rod. Mark location of holes and drill holes for 5/16" hardware. Attach with 5/16x3/4 Flange bolts, flat washers, and selflock nuts.

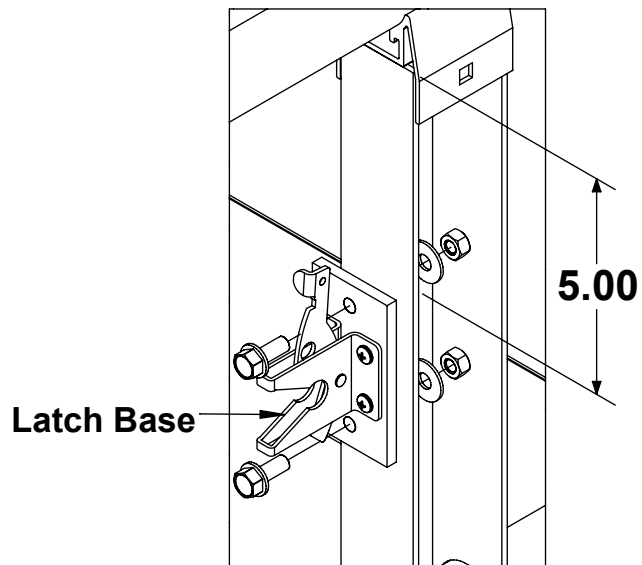

Fig.5.11

PRAIRIE VIEW INDUSTRIES, INC. LIMITED WARRANTY

1. LIMITED LIFETIME WARRANTY-THE FOLLOWING APPLIES TO ALL END PURCHASERS OTHER THAN RESIDENTS OF THE STATE OF CALIFORNIA*:

PRAIRIE VIEW INDUSTRIES, INC. warrants to the original end purchaser of the product is free from defects in material and workmanship under normal use and service. This warranty does not apply to any product that has been subject to misuse, abuse, neglect, alteration, accident, usage not in accordance with product instructions, acts of God, or improper installation or that has been used for rental purposes or repaired by someone other than PRAIRIE VIEW INDUSTRIES, INC. This warranty does not cover normal deterioration of the product due to wear and exposure.

*(FIVE YEAR WARRANTY-FOLLOWING APPLIES TO RESIDENTS OF THE STATE OF CALIFORNIA: For a period of five years after the purchase of the product by the original end purchaser of the product, PRAIRIE VIEW INDUSTRIES, INC. warrants to the original end purchaser of the product that the product is free from defects in material and workmanship under normal use and service. This warranty does not apply to any product that has been subject to misuse, abuse, neglect, alteration, accident, usage not in accordance with product instructions, acts of God, or improper installation or that has been used for rental purposes or repaired by someone other than PRAIRIE VIEW INDUSTRIES, INC. This warranty does not cover normal deterioration of the product due to wear and exposure.)

2. This warranty is limited to repairing or replacing, at the option of PRAIRIE VIEW INDUSTRIES, INC., any product that is returned to PRAIRIE VIEW INDUSTRIES, INC. and is reasonably determined by PRAIRIE VIEW INDUSTRIES, INC. to be defective. The repair or replacement of a defective product under this warranty will be made by PRAIRIE VIEW INDUSTRIES, INC. without charge of parts or labor. This excludes shipping or delivery charges to and from PRAIRIE VIEW INDUSTRIES, INC.'s place of business. If the product has been discontinued, PRAIRIE VIEW INDUSTRIES, INC. may replace the product with a new product of comparable value and function. PRAIRIE VIEW INDUSTRIES, INC. also reserves the right to refund the purchase price its exclusive warranty remedy.

3. Any claim alleging that the product fails to conform to this warranty may be made only by the original end purchaser and only while such purchaser owns the product. A defective product that is covered by this warranty must be returned, at the purchaser's expense, along with proof of date of original purchase (such as receipt, check or other document PRAIRIE VIEW INDUSTRIES, INC. deems acceptable that shows the date of purchase and the identity of the product purchaser), along with a description of the alleged defect, to PRAIRIE VIEW INDUSTRIES, INC., 2620 Industrial Drive, Fairbury, Nebraska 68352.

4. EXCEPT AS SET FORTH HEREIN, PRAIRIE VIEW INDUSTRIES, INC. MAKES NO WARRANTIES, EXPRESSED OR IMPLIED, AND PRAIRIE VIEW INDUSTRIES, INC. DISCLAIMS AND NEGATES ALL OTHER WARRANTIES, INCLUDING, WITHOUT LIMITATION, IMPLIED WARRANTIES OF MERCHANTABILITY, FITNESS FOR A PARTICULAR PURPOSE, CONFORMITY TO MODELS OR SAMPLES, OR ANY WARRANTIES OR INDEMNITIES AGAINST INTELLECTUAL PROPERTY INFRINGEMENT.

SOME STATES DO NOT ALLOW LIMITATIONS ON IMPLIED WARRANTIES, SO THESE LIMITATIONS MAY NOT APPLY TO YOU. IN NO EVENT WILL PRAIRIE VIEW INDUSTRIES, INC. BE LIABLE FOR ANY INDIRECT, SPECIAL, INCIDENTAL, OR CONSEQUENTIAL DAMAGES OR FOR ANY LIABILITY IN EXCESS OF THE PURCHASE PRICE OF THE PRODUCT.

5. Before using the product, the purchaser must first determine the suitability of the product for its intended use, and the purchaser assumes all risk and liability whatsoever in connection therewith.

6. No person, agent, distributor, dealer or company is authorized to change, amend or modify the terms of this warranty.

7. This warranty gives the purchaser specific legal rights, and the purchaser may also have other rights that vary from state to state.

8. The purchaser may not assign the purchaser's rights or obligations under this warranty without the prior written consent of PRAIRIE VIEW INDUSTRIES, INC.