

AccuGuard HP2

Modular Safety Beam System

INSTALLATION INSTRUCTIONS

Section 1

General Description

The AccuGuard HP2 is an active infrared 2-beam safety system. This modular system consists of a separate Control Module, two Transmitter Beam Heads with cables and two Receiver Beam Heads with cables. The beam heads are available for recess mounting and can be ordered with surface mount housings (HP2-SURFACE).

When a beam is interrupted, the Control Module signals the door to open. In the event of a power loss to the AccuGuard HP2, it will also signal the door to open, thus providing a failsafe system.

Figure 1

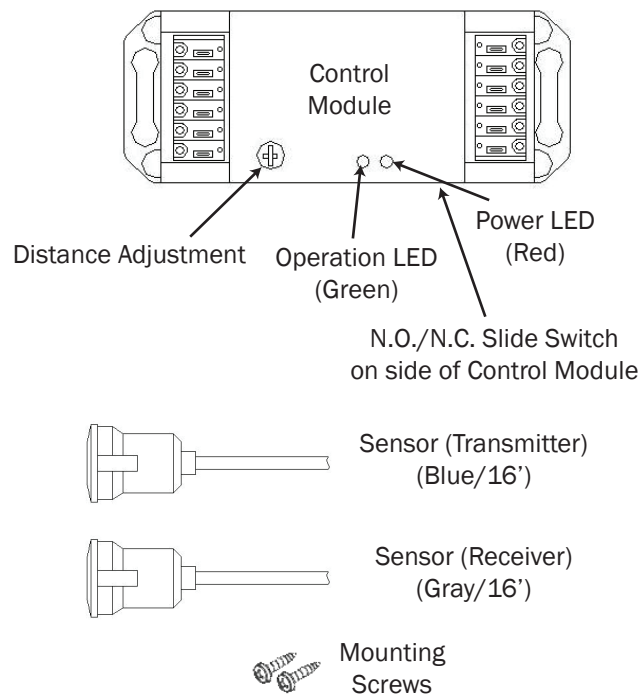

Section 2

Installation

Mounting (Fig. 2)

1. Mount the Control Module at the desired location in the operator housing using either the supplied screws or two-sided tape.
2. Drill 1/2" holes for each beam head at the desired location in the door frame, sidelight or rail.



NOTE: Opposing beam heads must be mounted at equal heights to function properly.

3. Insert cable through the 1/2" hole and pull cable up to the control module.



WARNING: Be careful not to snag the cable on any sharp edges. Damage to the cable can cause the device to malfunction.



WARNING: To avoid beam "cross talking" mount the Transmitter Beam Heads opposite of each other.

4. RECESS MOUNT: Push each Beam Head into the 1/2" holes.

SURFACE MOUNT: Attach the surface mount housing (with Beam Heads installed) at the desired location using the supplied screws ensuring the 1/2" holes are covered.

Wiring (Fig. 3)

1. Connect Beam Head cables to the Control Module (wiring diagram is printed on housing). Transmitter cables are blue and Receiver cables are gray.



NOTE: If only one set of beams is being used, the L1 Transmitter and Receiver connections must be used. L2 is empty.



WARNING: Any excess cable must be fastened down, clear of any moving parts.

2. Connect the Control Module outputs to the operator control - select N.O. (normally open) or N.C. (normally closed) **via the slide switch on side of the Control Module.**

N.O. = Contacts close when beams are broken or when power to the Control Module is interrupted (failsafe).

N.C. = Contacts close when beams are not broken.

3. Connect power supply to the Control Module: 12-24 V AC or DC.

Section 3

Set Up Instructions

Adjustments and Troubleshooting

With power applied, the Red LED on the Control Module should be solid red. If a beam is broken, the Green LED will light up (see LED Indication Table).

AccuGuard HP2

Modular Safety Beam System

INSTALLATION INSTRUCTIONS

LED Indication Table

	LED Indication
Power ON	Green and Red LED both light up Once then solid Red
L1 Found only	Green LED lights up 5 times and then Red LED On
L2 Found only	Red LED lights up 5 times and then Red LED ON
L1, L2 Found	Green and Red LED light up 5 times at same time and then Red LED On
None Found	Green and Red LED both light up continuously
L1 or L2	Green LED On while interrupted



NOTE: The HP2 set up is automatic, however manual sensitivity adjustment of the beams may be necessary. Manual sensitivity adjustment for each beam set is provided on the Control Module. If the Green LED does not light up when a beam is broken, reduce the sensitivity until it does.

Section 4

System Inspection and Instructions

*****EXTREMELY IMPORTANT*****

After final set-up, test unit(s) completely to ensure that proper coverage has been achieved (width, depth and location of the pattern must be tested).

After the installation and operational check of the system:

1. Ensure the AccuGuard HP2 is being used in compliance with ANSI/BHMA 156.10.
2. Place the proper labels on the door per ANSI/BHMA A156.10, A156.19 & BS 7036.
3. Instruct the owner of the door system operation and how to test it. This should be checked on a daily basis.
4. Instruct the owner on what to do if the door or any of its components become damaged.
5. Strongly recommend to the owner that the complete entry be inspected twice a year as part of the service agreement.

Section 5

Technical Data

Model..... AccuGuard HP2

Size:

Control Module..... 4 1/2"L x 1 3/4"W x 1"D
 Recess Mount
 Beam Heads..... 1/2" Dia. x 5/8"D
 Surface Mount Beam
 Head Housings..... 2 7/8"H x 1 1/2"W x 1"D
 Cable..... 2-conductor, 16 ft. ea.
 Color Coded: Blue = Transmitter
 Gray = Receiver
 Detection Method.....Active Infrared 950nm
 Detection Range..... 6 to 32 Feet
 Power Requirements.. 12-24V AC or DC
 (No Polarity Requirements)
 Light Resistance..... Sun—150,000 LUX
 Artificial—50,000 LUX
 Power Consumption... Standby 75mA, Active 100mA
 Relay Contacts..... Form C, Rated @ 1 Amp
 (resistive loads only)
 Relay Activation Time. 10 ms
 Relay Hold Time..... 500 ms
 Temperature..... -4 °F to 140 °F
 (-20 °C to 60 °C)

Mounting:

Control Module..... Any Available Door Header
 Space
 Recess Mount
 Beam Heads..... 1/2" Dia. Hole, 1" Deep
 Surface Mount
 Beam Heads..... Any Available Surface

Section 6

Warranty

MS Sedco guarantees this product to be free from manufacturing defects for 12 months from date of installation. Unless MS Sedco is notified of the date of installation, the warranty will be in effect for 12 months from the date of shipment from our factory. If, during the first 12 months, this device fails to operate and has not been tampered with or abused, the unit can be returned prepaid to the factory and it will be repaired free of charge. After 12 months, the unit will be repaired for a nominal service charge. **This limited warranty is in lieu of all other warranties expressed or implied, including any implied warranty of merchantability, and no representative or person is authorized to assume for MS Sedco any other liability in connection with the sale of our products. All warranties are limited to the duration of this written warranty. In no event shall MS Sedco be liable for any special, incidental, consequential or other damages arising from any claimed breach of warranty as to its products or services.**



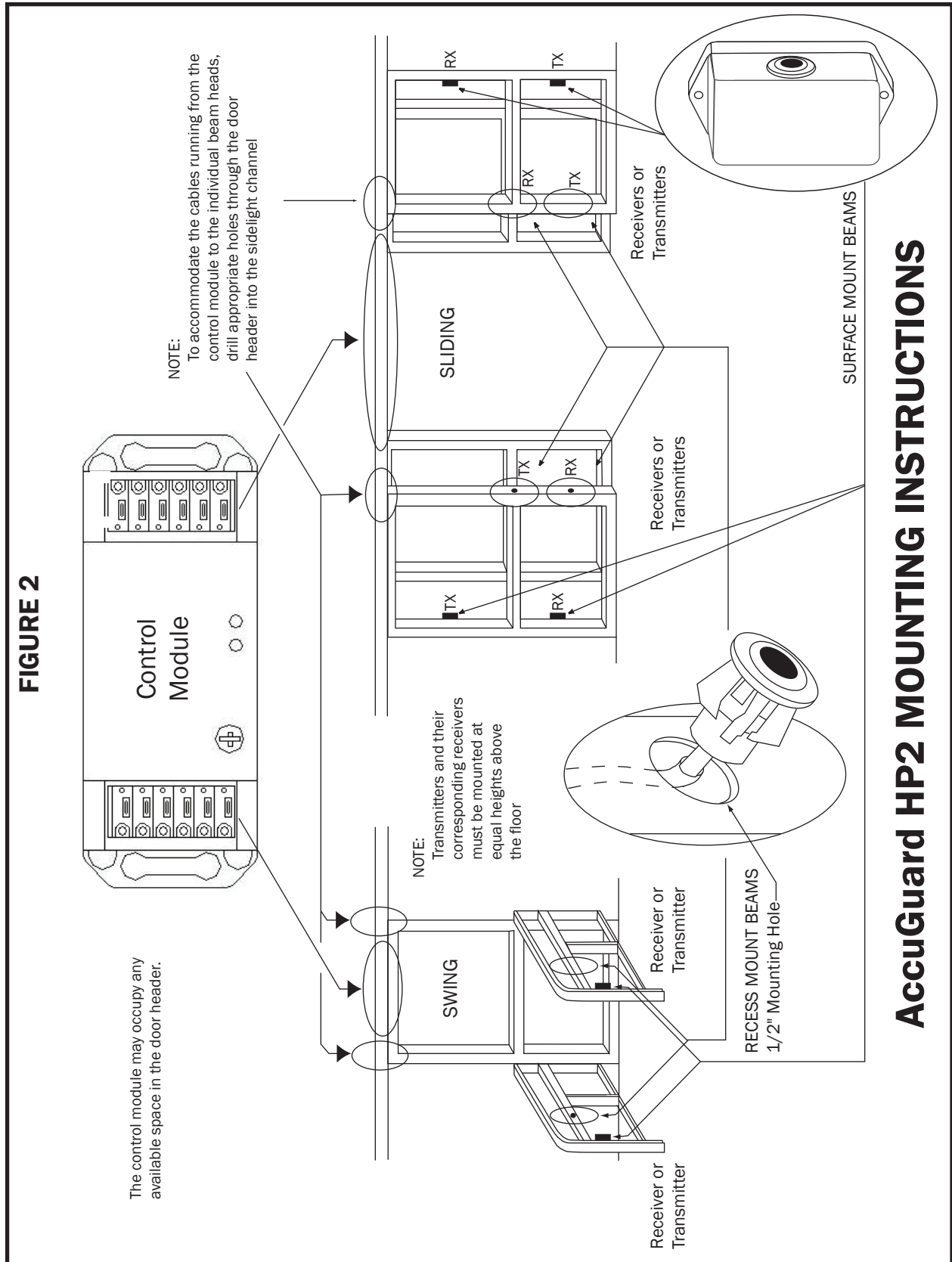

AccuGuard HP2 MOUNTING INSTRUCTIONS

AccuGuard HP2

Modular Safety Beam System

INSTALLATION INSTRUCTIONS

FIGURE 3

AccuGuard HP2 WIRING DIAGRAM

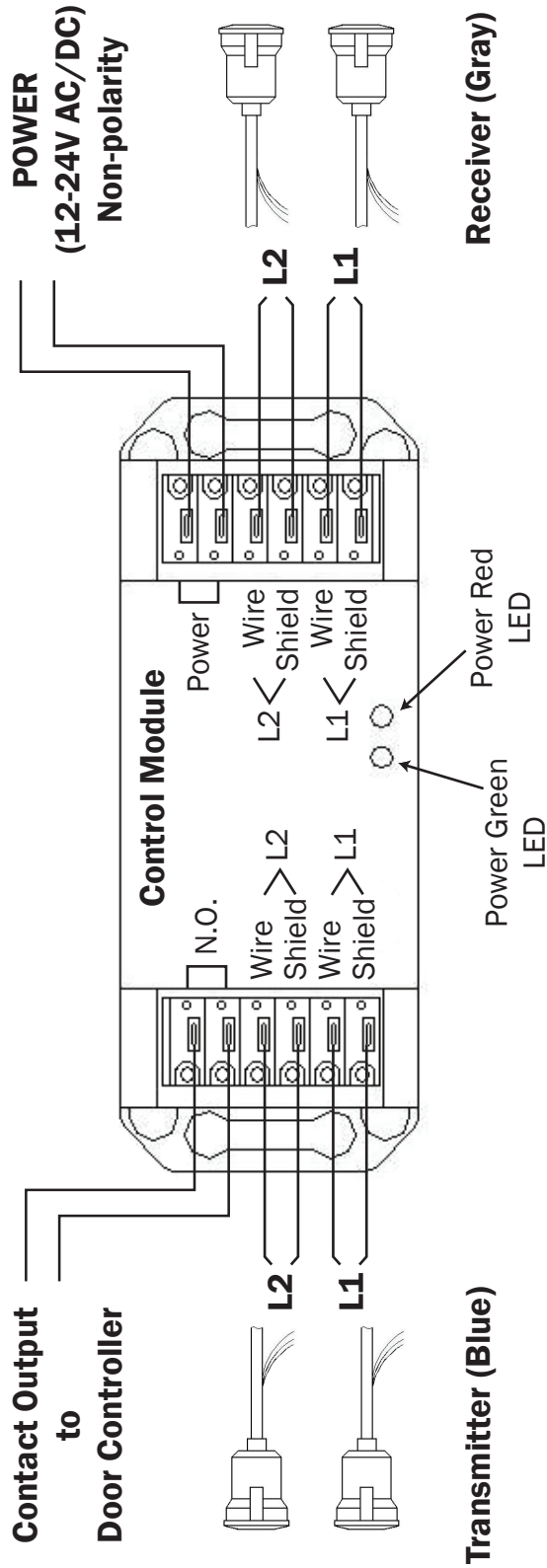

Beam Installation Guide

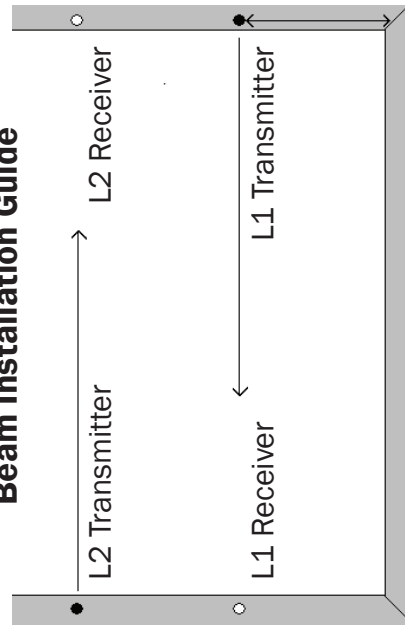

Ensure the Transmitter Heads are installed on opposite sides of the opening.